

# Manual PLS

## Professional LED Stacking

Manual Version 1.1

Date	Revision No.	Author	Checked	Approved	Description
22.04.2022	1.0	GJN	TSN	GHL	1.0
05.03.2024	1.1	GJN	TSN	GHL	Adding load distribution unit Adding chapter 9 (curved walls)



**These installation instructions must always be handed out to the persons that carries out the installation.**

## Table of contents

<b>1. Preamble</b> .....	<b>3</b>
1.1 Tools required.....	3
<b>2. Safety instructions</b> .....	<b>4</b>
2.1 Definition of qualified persons .....	4
2.2 Warnings.....	5
2.3 Caution.....	9
2.4 Risk Situations.....	10
<b>3. Scope of delivery</b> .....	<b>11</b>
<b>4. Overview of model numbers</b> .....	<b>12</b>
4.1 Compatible LED cabinets for LED Stacking product series .....	18
<b>5. Description of the product</b> .....	<b>19</b>
5.1 Technical introduction and intended use.....	19
5.2 Specifications.....	20
<b>6. Results of static analysis</b> .....	<b>21</b>
6.1 Environmental conditions and setup variants.....	21
6.2 Ballast weight .....	24
6.2.1 Using the Load Distribution Unit .....	26
6.4 Tensile connection to the ground .....	31
<b>7. Maximum stacking information</b> .....	<b>32</b>
<b>8. Step by Step installation procedure</b> .....	<b>33</b>
8.1 Prepare the installation .....	33
8.2 Installing the SKI and BASE .....	33
8.3 Connecting the STACKER .....	37
8.4 Installing the LED cabinets.....	38
8.5 Installing the DIAGONAL.....	41
<b>9. Curved Walls</b> .....	<b>43</b>
<b>10. Exemplary LED walls</b> .....	<b>44</b>

10.1 Infiled DB Series 15 by 10 .....	44
10.2 Absen AXpro 14x14 .....	46
<b>11. System maintenance and inspection re-examination.....</b>	<b>48</b>
<b>12. Disposal of components .....</b>	<b>49</b>
12.1 Metal parts and packaging .....	49
12.2 Disposal of entire devices.....	49

## 1. Preamble

The professional LED stacking products have been developed and manufactured with the highest care and attention. However, improper handling can cause a risk for safety and / or damage. Read these instructions carefully before handling and installing the product so that you can safely set-up and use the system. In the following pages, you will find all the information needed for a safe and fast installation.

After the installation is done properly, you can enjoy all the features of your new product.

Copyright © 2022 EXACT solutions GmbH. All rights reserved.

### 1.1 Tools required

The tools required are:

- 5mm Allen key to tighten the BASE-Profile to the LED-SKI
- 6mm Allen key to level the LED-SKI, SKI-Extensions and SINGLE Foot



*Figure 1 Allen key (hex key)*

- 13mm hexagon wrench key to adjust BASE lever
- 19mm hexagon wrench key to secure the Foot-adjustment



*Figure 2 hexagon wrench key*

## 2. Safety instructions



These installation instructions must always be handed over to the person who is carrying out the installation.

Read these instructions carefully before installing the system.

### 2.1 Definition of qualified persons



Note: The definitions provided here are in parts translated from German standard DGUV 315-390, chapter 4. The information provided in the following section is just an excerpt of DGUV 315-390. There is no guarantee for a flawless translation. For further details see DGUV 315-390 and consider your local laws and regulations.

#### Qualified Person (Technical Expert)

Qualified person is qualified through relevant technical professional training, through knowledge of the operating methods as well as professional experience and recent professional activity in the field of event technology.

The required qualifications include in particular:

- Knowledge of applicable regulations and technical rules
- Required information from the manufacturer of the mechanical event technology equipment, that needs to be tested
- Knowledge of the risk assessments of the mechanical work equipment for event technology, that needs to be tested

A person can be considered as qualified when it has been thoroughly informed and/or trained about the assigned task and the possible dangers that can occur in case of improper behaviour and / or not observing precisely the installation instructions.

#### Authorised Expert Inspector

Authorized experts are persons who:

- have completed a technical degree at a technical university or scientific college
- be able to demonstrate at least three years of experience in the design, construction, maintenance or testing of mechanical work equipment for event technology, including at least six months of experience in testing this equipment
- have special knowledge of the relevant regulations
- are familiar with the operation of the event technology
- have the facilities and documents required for the examination and
- keep their professional knowledge up to date

# Manual PLS (Professional LED Stacking)

---

- attest a certificate of qualification from the DGUV (authorization of a statutory accident insurance institution to act as an expert according to § 36 DGUV regulation 17 or 18 "Event and production facilities for scenic representation")

The requirements contained in the BetrSichV in conjunction with TRBS 1203 for inspectors for the verification of mechanical work equipment for event technology are met by the authorized experts in accordance with DGUV regulation 17 or 18 "Event and production facilities for scenic representation". These meet the requirements for inspectors for the work equipment mentioned above.

## 2.2 Warnings



The LED Stacking product series is intended for use by fully qualified, trained and competent persons to provide safe and secure installation and adjustment of LED walls.



Warning: Handling only by instructed, qualified and authorised person with a minimum age 18 years and of sound mind.



For indoor usage only

For indoor usage only! Use the LED Stacking product series only in a closed environment (conference rooms, theatres, convention halls, etc.) where there is no wind, moisture, excessive heat, salty air etc.



Make sure that only the designated LED cabinets are installed with the products of LED Stacking! Do not try to use it with other products because serious accidents can occur!



Do not remove or replace any parts of the LED Stacking product series on your own. Contact the manufacturer or service partner in case of damage or loss. Removing or replacing parts by non-certified companies or people might result in serious accidents and death.

### **Only use the LED Stacking and its components for its intended use.**

- If this product is used for something else than its intended use, serious accidents and death may result. See chapter 5.1 Technical introduction and intended use

### **Installation work should only be carried out by a qualified technician.**

- If this product is not installed correctly, serious accidents and death may result.

### **Do not use the products of the LED Stacking series outdoor.**

## Manual PLS (Professional LED Stacking)

---

- This product is made only for indoor usage. If the product is mounted outdoor, there are many influences like wind or rain that can have an effect on the stability of the whole system.
- This can cause property damage, serious accidents and death.

**A visual inspection must be done prior to every installation, in which the system is involved. The inspection must be performed by a qualified person.**

- All parts of The LED Stacking must be inspected in detail prior to any usage
- Only if the product and all its components are in a flawless condition, it is safe to use the system.
- Using a LED Stacking part which has damages, missing parts or the like can cause serious accidents and death.
- For further details, see chapter 11. System maintenance and inspection re-examination

**Only use LED cabinets that are specified by the manufacturer to be used with the LED Stacking System. When mounting the LED cabinets to the system, use all screws, locking pins, clamps and cotter pins that are specified by the manufacturer. Make sure to tighten the screws safely**

- It is mandatory to use all screws, locking pins, clamps and cotter pins that the manufacturer defines to mount the LED cabinet to the system. Use only the ones that are clearly specified.
- For a safe installation the screws must be tightened with the provided torque
- Using the wrong screws, locking pins, clamps and cotter pins is highly dangerous. Tightening the screw with a too low torque can cause the screw to loosen itself. Tightening the screw with a too high torque might cause structural damage to the screw or the thread inside the LED cabinet.
- Ignoring these instructions can cause the parts or the whole system to fall down and with this can cause death, serious injuries or product damage.

**Make sure that the structure/surface where the LED Stacking system is built up, is capable of carrying the overall weight of the system plus the weight of all additional equipment as well as other potential systems.**

- Prior to any installation, you must do a visual inspection to make sure that the system is in a good condition. For more information, please refer to chapter 11. System maintenance and inspection re-examination

## Manual PLS (Professional LED Stacking)

---

- Prior to any installation, you must do a precise calculation what the complete system weight will be. (Weight of all components, LED cabinets, cables, counter weights)  
Only use the weights, given in this manual.
- Ignoring this might cause significant damage to the product and serious accidents or death may result

**Make sure to use only approved and recommended LED cabinets with the LED Stacking system product. Only use approved and recommended accessories.**

- Do not use other LED cabinets than the ones recommended and approved.  
Otherwise, using incompatible LED cabinets may lead to serious injuries, death and property damage
- Do not use other accessories than the ones recommended and approved. Otherwise, using insufficient accessories may lead to serious injuries, death and property damage
- See chapter 4.1 Compatible LED cabinets for LED Stacking product series

**Make sure not to exceed max. weight loads.**

- Do not overload the products of the LED Stacking system or of any accessories and make sure the overall weight is within working specifications of the accessories.  
Please also refer to chapter 6. Results of static analysis
- Overloading the accessories and other equipment can cause serious accidents and death

**Do not stack more LED cabinets than allowed by the manufacturer**

- Do not exceed the maximum number of stacked units as this may cause the whole system or parts to tilt and to fall down. Refer to 7. Maximum stacking information
- Ignoring this might cause significant damage to the product and serious accidents or death may result

**Make sure to follow the results of the static calculations**

- Follow the rules given by the static calculations.
- Ignoring this might cause significant damage to the product and serious accidents or death may result

**When using the adjustment features, locking pins, screws etc of the LED Stacking products, never apply significant force.**



## Manual PLS (Professional LED Stacking)

---

- When using components such as the adjustment features, locking pins and screws of the products, never apply force. All those features shall work smoothly and do not require significant force.
- If significant force is necessary, the cause may be a faulty part and this should not be ignored.
- Ignoring this, might cause significant damage to the product and serious accidents may result

**Service work shall only be done by qualified personnel that is authorized by the manufacturer. Furthermore, only original spare parts shall be used.**

- Unauthorized personnel shall never do service work on the products, as service work requires special training and knowledge
- Spare parts must always be original ones, provided by the manufacturer
- Not observing these rules on service work ends with immediate effect the responsibility of the manufacturer and, where applicable, warranty is irrecoverably lost. The product is no longer safe to use. This may cause serious accidents or death and property damage.

**The LED Stacking system shall never be used for climbing.**

- The system is not made to be used for climbing or as some sort of a ladder
- Ignoring this may lead to serious injuries, death and property damage

**Do not place anything under the LDU (Load distribution unit)**

- It is very important that the LDU and the counterweight transfer all their weight to the LED stacking system.
- If this is not considered, the counterweight will not have the wanted functionality and serious accidents can occur.

**Do not place anything any weight on the unattached end of the LDU (Load distribution unit).**

- Otherwise, the LDU may tilt over.
- Ignoring this may lead to serious injuries, death and property damage

**It is mandatory to position the counterweight so that its centre of gravity (COG) is aligned with the centre of the Load distribution unit (LDU).**

- There is a triangle marking on the top side of the LDU which indicates the centre of the LDU. See Figure 6 for further details.

# Manual PLS (Professional LED Stacking)

---

- Ignoring this will change the functionality of the counterweight and with this may lead to serious injuries, death and property damage

## **Make sure that the counterweight is positioned safely on the LDU (Load distribution unit).**

- It must be avoided that the counterweight may fall down from the LDU. If the counterweight cannot be securely fastened on the LDU, it is not allowed to use it in that combination and users need to find an alternative solution. Contact us if support is needed.
- Ignoring this might cause significant damage to the product and serious accidents or death may result

## **2.3 Caution**

### **Minimum two persons are required to install the Professional LED Stacking products.**

- With regard to the overall weight of all necessary installation devices, make sure to handle those with at least two people.

### **Periodic inspections are mandatory**

- Depending on local laws and regulations owners / users must do periodic inspections of all components.

### **Do not place unsecured accessories like tools or electrical devices (converter, video player etc) into the wall build with the LED Stacking**

- These devices may fall down and causes serious accidents or even death to people who are situated near the installation.
- The additional weight of every device added to the system must be considered. Contact the manufacturer for any questions.

### **Use suitable transport boxes / flight cases to protect the products during transport. Handle with care.**

- When transporting the LED Stacking products, make sure you are using a flight case that protects and damps impacts during transport.
- Transport shall be carried out gently to avoid damages through falling or similar impacts.
- During transportation, heavy impacts might damage the product. In this case, the stability and safety of the system is at high risk. This can lead to accidents, death and property damage.

### **Use only gentle cleaning agents to avoid damage**

## Manual PLS (Professional LED Stacking)

---

- Cleaning may be done with a soft cloth and a little bit of warm, slightly soapy water
- Do not use any oil, acid etc. on the products or its components. This may damage the system.

### **Incorrect disposal is a risk to humans and nature**

- Disposal must be done in accordance with local laws and regulations. Contact the manufacturer in case of any questions.

## **2.4 Risk Situations**

### **Risk of injury due to the possibility of falling objects during the assembly or disassembly of the PLS.**

- Protection objective: Avoid injury from falling parts.
- Wear appropriate safety shoes, gloves and helmet.
- Make sure the area next to the PLS is clear and no person is present during installation.

### **Risk of hitting the head with the PLS during the set-up process.**

- Protection objective: Avoid injury from hitting the head.
- Wear a helmet.

### **Incorrect installation may lead to certain parts of the PLS or the entire PLS to fall down.**

- Protection objective: Prevent personal injury and property damage.
- Double check the PLS components and its installation.
- Read the PLS series manual carefully.
- Always level the PLS-System exactly horizontal in all axes before adding the LED-Cabinets. Double-check the alignment during and after installation. Make sure the ground is stable and flat.
- Always use all locking bolts to secure the stacker and diagonals of the PLS-System
- Always ensure that all LED-Cabinets are locked correctly, especially to the baseplate of the PLS-System. Double check the correct locking during and after installation.

### **Insufficient load capacity of the supporting structure may lead to certain parts of the PLS or the entire PLS to fall down.**

- Protection objective: Prevent personal injury and property damage.
- Provide adequate dimensioning of the supporting structure. The supporting structure must be able to support the combined weight of all the equipment attached to it.

## Manual PLS (Professional LED Stacking)

---

- Ensure correct installation of the supporting structure.

### **Usage of unsafe ladders/steps/scaffolding may lead to serious personal injuries**

- Protection objective: prevent personal injury by using only safe ladders/steps/scaffolding.
- Use only appropriate and safe equipment
- Always follow the documentation of the manufacturer of the provided ladders/steps/scaffolding
- Use personal safety equipment if necessary

### **Injuries produced by caught limbs during setup and dismantle**

- Protection objective: Prevent personal injury by using safety gloves.
- During setup and dismantle always watch your hands and fingers on connection-points and while attaching splints and bolts. Always be focused on the construction and do not act hectic.

## 3. Scope of delivery



Note: Please check the delivery for completeness and damage immediately after you receive the shipment. Please contact your vendor in case of missing or damaged parts.

As a reference check the drawings of each component of the PLS that you purchased to see if all parts are complete.

## 4. Overview of model numbers

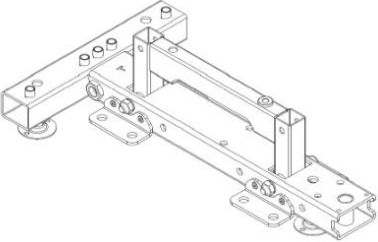
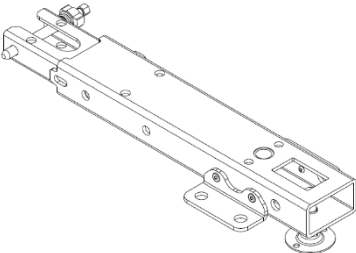
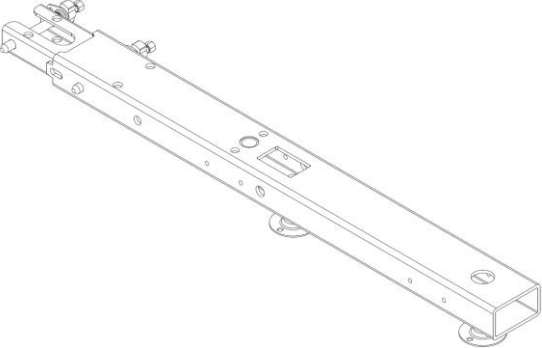
Name, Article Number and rendering	Description
<p data-bbox="220 421 320 488"><i>The SKI</i> LED-SKI</p> 	<p data-bbox="802 421 1369 566">The SKI is a standard part, fits to all LED cabinet types On top of the front of the SKI, the BASE will be mounted.</p>
<p data-bbox="220 761 528 828"><i>The SKI Extension Short</i> LED-EXN-S</p> 	<p data-bbox="802 761 1374 943">The SKI Extension Short is a standard part, that fits all LED cabinet types. It connects to the LED-SKI. The SKI Extension extends the SKI to its backside.</p> <p data-bbox="802 954 1374 1021"><b>i</b> Note: The Extension is also referred as “cantilever” in the following page</p>
<p data-bbox="220 1075 520 1142"><i>The SKI Extension Long</i> LED-EXN-L</p> 	<p data-bbox="802 1075 1374 1256">The SKI Extension Long is a standard part, that fits all LED cabinet types. It connects to the LED-SKI. The SKI Extension extends the SKI to its backside. This article is the long version.</p> <p data-bbox="802 1312 1374 1379"><b>i</b> Note: The Extension is also referred as “cantilever” in the following page</p>

The BASE Profile with BASE Plates  
LED-Bx-y-z

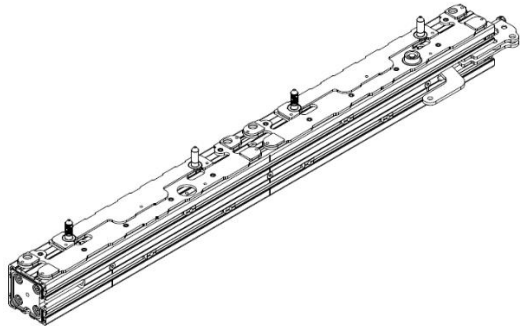

The BASE consists of the BASE Profile and the BASE Plates.

The BASE Profile is a semi standard part and differs in its length depending on the width of the cabinet.

The BASE Plates are made for specific LED cabinet types.

In terms of the length of a BASE Profile there are three different versions:

- For 1 LED cabinet (Single BASE)
- For 2 LED cabinets (Double BASE)
- For 3 LED cabinets (Triple BASE)

The article number starts with LED-B and is followed by further details

LED-Bx-y-z

With:

- x: width of the cabinet in mm  
for example: "500"
- y: length of the BASE profile in amount of cabinets next to each other  
for example: "2"
- z: Description of LED Cabinet type,  
for example "ILDB"

The rendering on the left shows the article LED-B500-2-ILDB



BASE Profile made for 500 mm wide cabinets

The BASE Profile has an overall width of 2 cabinets next to each other

The BASE Plates are specifically made for ILDB = Infiled DB Series

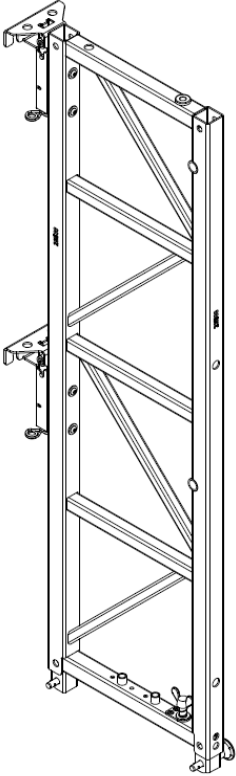

Note: The BASE Profile with a width of one LED Cabinet is mainly used for curved applications. For this reason these BASE Profiles cannot be attached with a connector to other BASE Profiles.

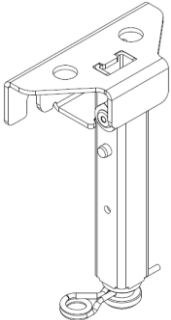
<p><i>The STACKER</i> LED-STR-x</p> 	<p>The STACKER is a semi standard part and differs in its height depending on the height of the cabinet. The STACKER is mounted on top of the SKI and is located right behind the LED cabinets. Following STACKER are mounted on top of the ones below. One STACKER usually has the height of two LED cabinets. STACKER differs in their height. Overall, there are different heights: 300, 466, 480, 500 mm and more The height of the STACKER correlates with the height of the LED cabinet.</p> <p>The article number of a STACKER starts with LED-STR followed by further details: LED-STR-x With: - x: height of the STACKER</p> <p>For example, LED-STR-500 is a STACKER made for LED cabinets with a height of 500 mm</p> <p> Note: The illustration on the left shows the STACKER with CLAMPS</p>
<p><i>The CLAMP</i> LED-CLP-x</p> 	<p>The CLAMP is the connection between the STACKER and the SCREW Set that is fixed to the LED cabinet. The CLAMP is not a standard part. A CLAMP is always made for a specific LED cabinet. The article number of a CLAMP starts with LED-CLP followed by further details: LED-CLP-x With: - x: the model of LED Cabinet</p> <p>For example, LED-CLP-ILDB is a CLAMP made for Infiled DB Series.</p>

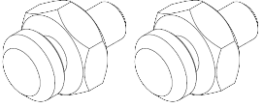
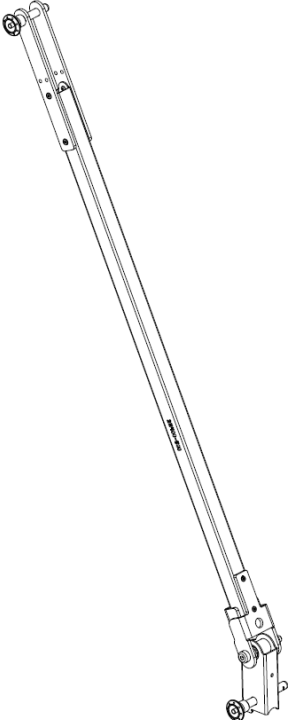
<p><b>SCREW Set</b> LED-SRES-xy</p> 	<p>The SCREW Set is the connection between the CLAMP and the LED cabinet, so it is not a standard part. A SCREW Set is always made for a specific LED cabinet.</p> <p>The article number of a SCREW Set starts with LED-SRES followed by further details: LED-SRES-xy With:</p> <ul style="list-style-type: none"><li>- x: definition of screw thread (e.g. M8 or M10)</li><li>- y: definition of screw material. This can be: Zn: galvanised steel</li></ul> <p>For example, LED-SRES-M8Zn is a SCREW Set of two pieces with an M8 thread and made of galvanised steel</p>
<p><b>The DIAGONAL</b> LED-DIL-xy</p> 	<p>The DIAGONAL is the connection between the SKI Extension and to an upper STACKER.</p> <p>A DIAGONAL is defined by the height of the LED cabinet and, if it is a Short or a Long Version. The Short version connects to the upper part of the first stacker. The Long version connects to the upper part of the second stacker.</p> <p>The article number of a DIAGONAL starts with LED-DIL followed by further details: LED-DIL-xy With:</p> <ul style="list-style-type: none"><li>- x: can be S or L whether it's Short or Long version</li><li>- y: height of the LED cabinet in mm</li></ul> <p>For example, LED-DIL-L500 is a DIAGONAL in Long version made for LED cabinets with 500 mm height. The Long version is also available as folding function. In this case the above named example would be named LED-DIL-L500f where the " f " stands for foldable.</p>

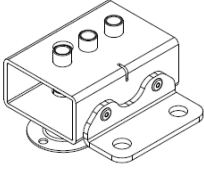
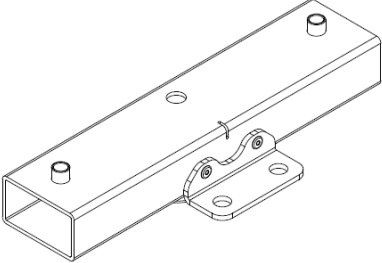
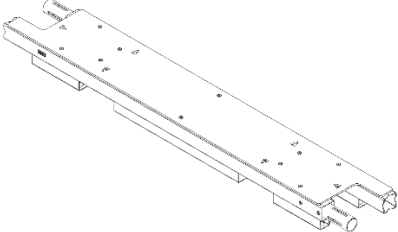

## Manual PLS (Professional LED Stacking)

<p><i>THE SINGLE Foot</i> LED-SKI-SF</p>  <p>A 3D perspective drawing of a rectangular metal component with two circular holes on top and a mounting bracket on the side.</p>	<p>The SINGLE Foot is a standard part and fits the BASE Profile. It can be used at the edges of the first and the last BASE Profile to increase stability. In this case, the article number is LED-SKI-SF.</p>
<p><i>THE SINGLE Foot Curved</i> LED-SK-SFc</p>  <p>A 3D perspective drawing of a long, narrow metal component with a curved mounting bracket on one end.</p>	<p>The SINGLE Foot Curved is a standard part and fits the single BASE Profile that is made for the width of only 1 LED cabinet. The SINGLE Foot Curved is necessary for curved applications where only BASE Profiles for 1 LED Cabinet are used.</p>
<p><i>The Load Distribution unit</i> LED-LDU-x</p>  <p>A 3D perspective drawing of a long, narrow metal component with multiple holes and a mounting bracket on one end.</p>	<p>The Load distribution unit is a semi standard part and fits the SKI Extension Short and SKI Extension Long. The Load distribution unit can be used to position the balance weight to the cantilever. The LDU differs in its length depending on the width of the cabinet.</p> <p>The article number of a LDU starts with LED-LDU followed by further details: LED-LDU-x With:</p> <ul style="list-style-type: none"><li>- x: width of the cabinet in mm for example: "500"</li></ul>

# Manual PLS (Professional LED Stacking)

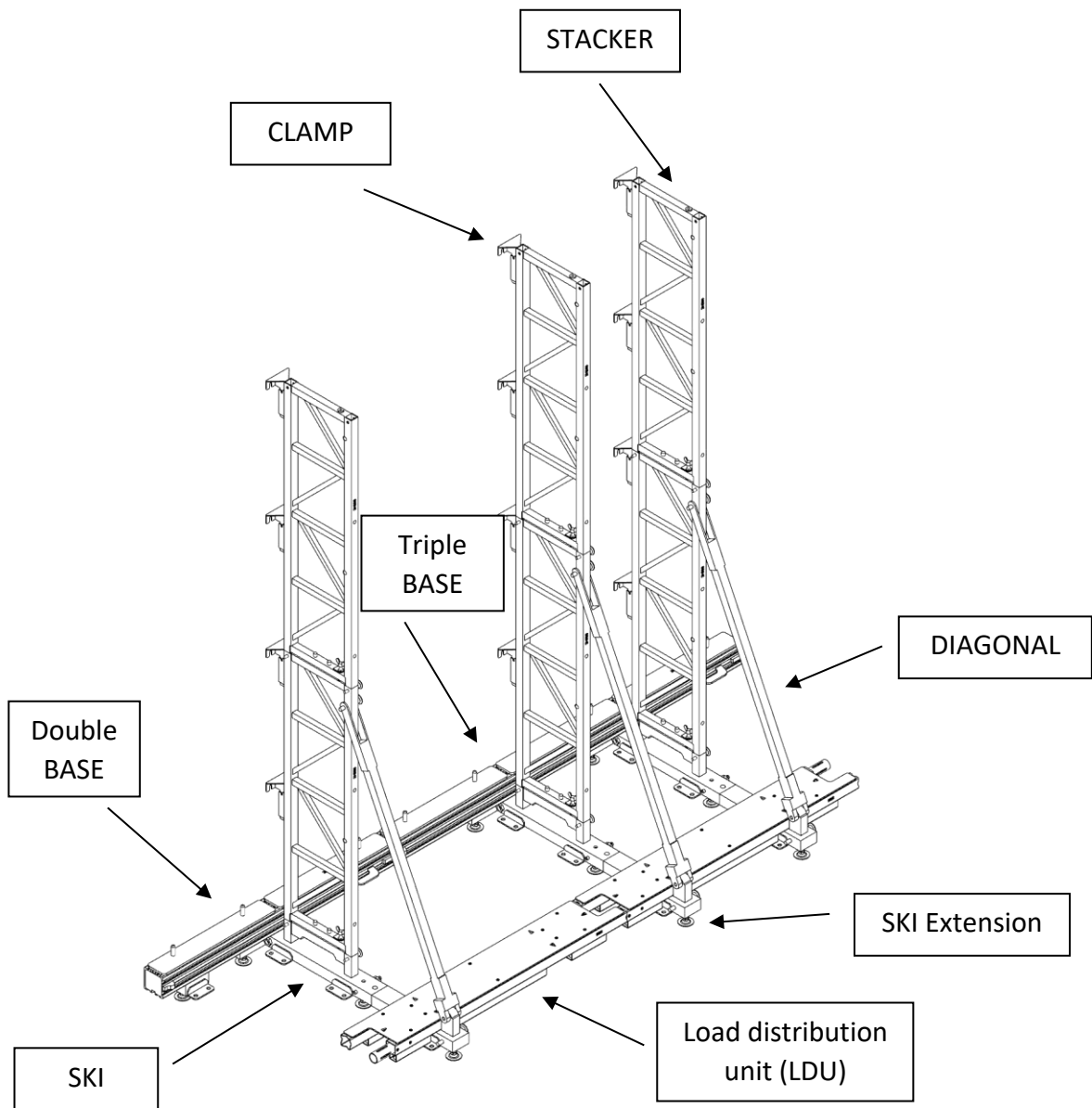

Figure 3 Exemplary overview of PLS components without LED Cabinets

## 4.1 Compatible LED cabinets for LED Stacking product series

LED Manufacturer and product
Infiled DB series
Infiled S1.8
Theatrixx xVision Nomad 2.6
LEDitgo rX2 and rX3
Innlights RQ3HE
Absen AXpro
Unilumin Upad IV
...



This is an excerpt of compatible LED cabinets. Please contact us for more information.

## 5. Description of the product

### 5.1 Technical introduction and intended use

An LED Wall is set up using multiple LED Cabinets to create large displays. There are several manufacturers that provide different LED Cabinet models.



Figure 4 Exemplary image of backside and frontside of LED Cabinet (Infiled DB series)

The PLS (Professional LED Stacking) is a mechanical solution for mounting LED Cabinets together in a wall. It uses standardised and non-standardised components. Standard components can be used for different LED Cabinet types and manufacturers. Non-standard components are specifically designed for a certain LED manufacturer and model. Those non-standard components are usually the parts of the PLS that directly connect to the LED Cabinet such as CLAMP and BASE Plate.

There are clear rules on how to set up a LED Wall using PLS. These rules result from static calculations and define parameters such as maximum height, ballast weight, needed components etc. Static calculations are made for each LED Cabinet model separately and differ.



This manual does not list the results of the static calculation of each LED Cabinet product. They must be sourced separately. Contact EXACT solutions if you have further questions.



If static calculations are not available, they must be made. Do not try to use LED Cabinets that are not specifically defined as compatible with PLS.



The static analysis and verification of the LED cabinets are not part of the Professional LED Stacking and must be done separately. It is assumed that the LED Cabinets can distribute the loads to the Professional LED Stacking System such as the STACKERS. The loads are for example a potential wind load. Contact your LED product supplier for proofs of stability of the LED product like maximum setup options, resistance to wind load etc.

# Manual PLS (Professional LED Stacking)

---



The Professional LED Stacking system is made only for indoor usage. Outdoor usage is prohibited and highly dangerous.



Only use LED cabinets that are specified by the manufacturer to be used with the LED Stacking System. When mounting the LED cabinets to the system, use all screws, locking pins, clamps and cotter pins that are specified by the manufacturer. Make sure to tighten all the screws safely



PLS saves costs as many parts can be reused for other LED Cabinets.

## 5.2 Specifications

Parameter	Value
Operating temperature [°C]	0 - 45
Operating rel. humidity [%rH]	10 - 75
Operation area	Indoor in closed rooms

## 6. Results of static analysis

### 6.1 Environmental conditions and setup variants

The static analysis of the LED stacking construction examines different load situations which will be briefly explained in the following section.

#### Horizontal load of 0,125 kN/m<sup>2</sup>

This is a load that is equivalent to a potential wind load in indoor environments. This load applies force to the whole LED wall surface. It is for example important in exhibition halls where wind has to be taken into consideration. The load of 0,125 kN/m<sup>2</sup> results from various technical guidelines of German exhibitions. It is applied to a wall height of up to 4,0 m. Above 4 m the load is divided in half. Aerodynamic coefficients are not considered.

<= 4,0 m wall height:	0,125 kN/m <sup>2</sup>
> 4,0 m wall height:	0,063 kN/m <sup>2</sup>

#### Horizontal impact by persons

This is the theoretical impact of persons hitting the wall. It is considered as 50 kg at a height of 1,0 m above floor.

Note: The horizontal impact by persons is never considered in Setup Variant 3 (see Table 1).



The equivalent load of 0,125 kN/m<sup>2</sup> results from various technical guidelines of German exhibitions. If, due to any reason, there may be higher horizontal loads (e.g. wind load), do not use the product without consulting the manufacturer.



The Professional LED Stacking system is made only for indoor usage. Outdoor usage is prohibited and highly dangerous.



The horizontal impact by persons will not be considered by the setting variant 3 (cantilever to the front). Here, the horizontal impact must be avoided constructively.

Overall, the static calculation analyses three different environmental conditions depending on the given circumstances:

- Condition 1: **Without** horizontal equivalent load  
**With** impact of persons
- Condition 2: **With** horizontal equivalent load  
**With** impact of persons
- Condition 3: **With** horizontal equivalent load  
**Without** impact of persons

# Manual PLS (Professional LED Stacking)

Furthermore, there are up to five different setup variants, as following illustrated in Table 1:

- Setup variant 1: stacker without cantilever
- Setup variant 2: stacker with cantilever to the backside
- Setup variant 3: stacker with cantilever to the front
- Setup variant 4: stacker with long cantilever to the backside and diagonal bracing for the height of 4 cabinets
- Setup variant 5: stacker with short cantilever to the backside and diagonal bracing for the height of 2 cabinets



Make sure that the structure/surface where the LED Stacking system is built up is capable of carrying the overall weight of the system, plus the weight of all additional equipment, as well as other potential systems.

Setup Variant 1	Setup Variant 2	Setup Variant 3	Setup Variant 4	Setup Variant 5
				
stacker without cantilever	stacker with cantilever to the backside	stacker with cantilever to the front	stacker with long cantilever to the backside and long diagonal	stacker with short cantilever to the backside and short diagonal bracing

Table 1 Setup variants

## Manual PLS (Professional LED Stacking)

---

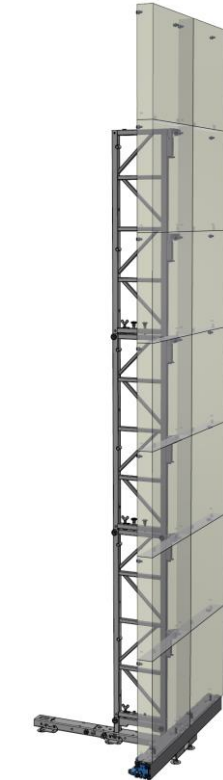
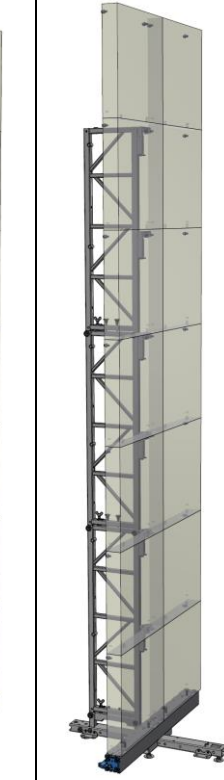
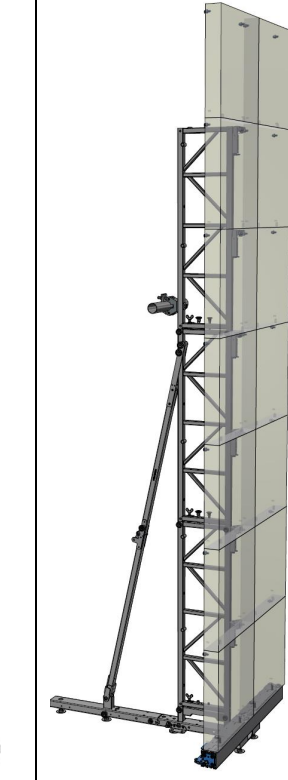
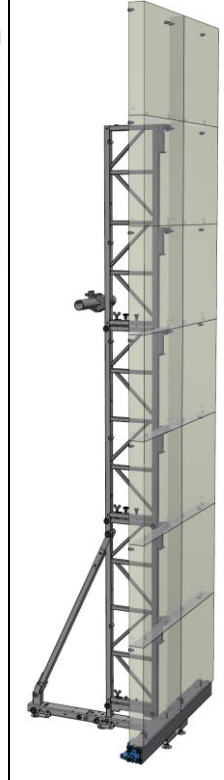

Not all products and respectively not all static calculations include all five Setup Variants. If a certain Setup Variant is not listed in the static calculation, it is forbidden to setup up a system in that way.

Depending on the environmental condition and the size of the wall, users have to choose the correct setup variant and components as well as the correct ballasting weight. This is described in the following and in the corresponding static calculations. See Figure 5

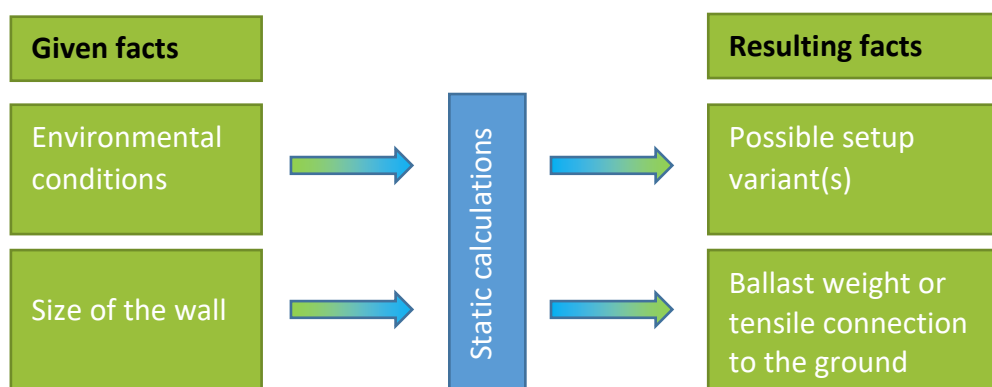

Figure 5 Flow chart determination of correct resulting facts



The STACKERs must have a maximum distance of usually approx. 1,0 m to each other. This means usually the STACKER stands behind every second vertical splice of the LED Cabinets. As a result, each STACKER bears the max load of two LED Cabinets. Note: The maximum distance may differ, depending on the width of one LED cabinet.



The stackers must be built up to the top of the LED Wall. Depending on the results of the static calculation, it might be allowed to leave the two upper LED cabinets without a stacker. Users have to revalidate this by checking the static analysis.



The centre of the ballast must be positioned and dimensioned according to the static calculations. See chapter 6.2 Ballast weight



Static calculations can be provided and it is mandatory for every user to know the static calculations and with this the correct way to set up the system.



The static analysis and verification of the LED cabinets are not part of the Professional LED Stacking and must be done separately. It is assumed that the LED Cabinets can distribute the loads to the Professional LED Stacking System such as the STACKERs. The loads are for example a potential wind load. Contact your LED product supplier for proofs of stability of the LED product like maximum setup options, resistance to wind load etc.



### 6.2 Ballast weight

The ballast weight must be chosen correctly by following the static calculation. The setup variants 1 and 3 do not require ballast weight. Neither do they offer the possibility to position ballast weight. For variant 1 see chapter 6.4 Tensile connection to the ground.

The setup variant 2, 4 and 5 require ballast weight. The ballast weight has to be positioned at the back of cantilever beam.



See Table 2 for finding the correct position of the ballast weight indicated by the blue arrow and the technical symbol for centre of gravity.



As illustrated in Table 2 the weight has to be positioned with its centre of gravity at a distance of 150 mm from the back of the extension. This is mandatory and cannot be varied.

# Manual PLS (Professional LED Stacking)

Setup Variant 2	Setup Variant 4	Setup Variant 5
		
<p>stacker with cantilever to the backside</p>	<p>stacker with long cantilever to the backside and diagonal bracing for the height of 4 cabinets</p>	<p>stacker with short cantilever to the backside and diagonal bracing for the height of 2 cabinets</p>

Table 2 Ballast weight positions

## 6.2.1 Using the Load Distribution Unit

For an easy installation of the ballast weight, you can use our Load Distribution Unit (LDU). It varies in its length, depending on the width of a single LED cabinet.

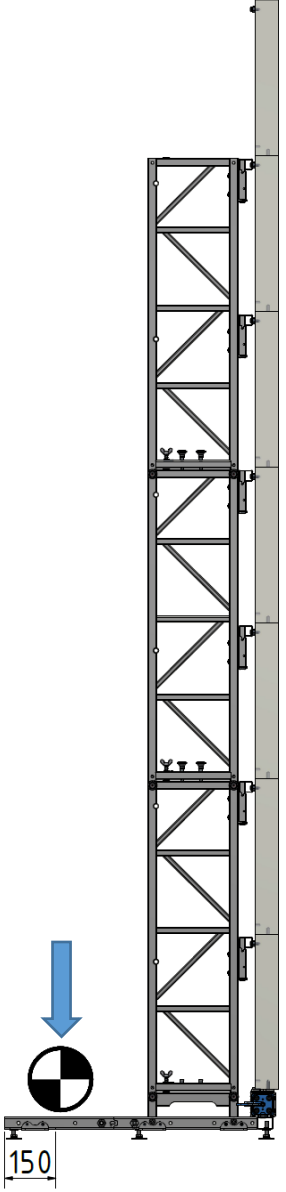
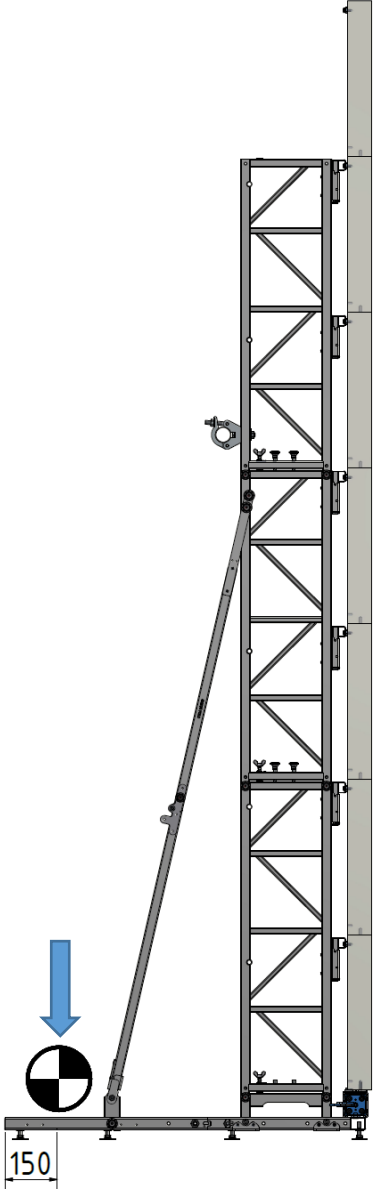
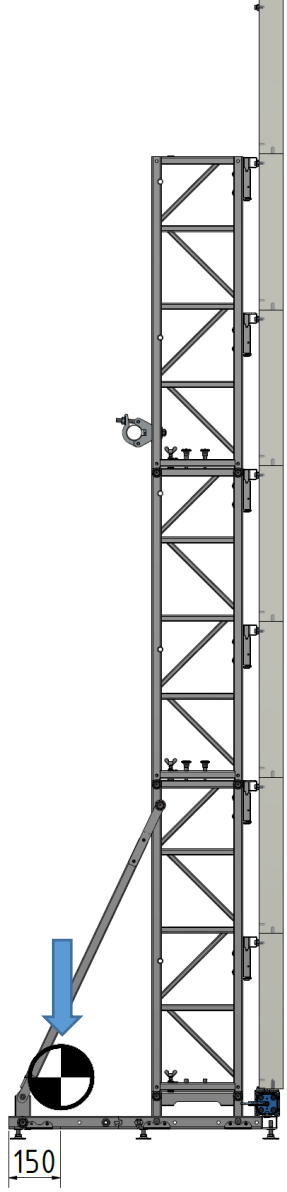

Do not place anything under the LDU. It is very important that the LDU and the counterweight transfer all their weight to the LED stacking system. If this is not considered, the counterweight will not have the wanted functionality and serious accidents can occur.



Do not place any weight on the unattached end of the LDU. Otherwise it may tilt over.



Only use the LDU for straight wall setup.



It is mandatory to position the counterweight so that its centre of gravity (COG) is aligned with the centre of the LED-LDU-500. There is a triangle marking on the top side of the LDU which indicates the centre of the LDU. See Figure 6 for further details.



Make sure that the counterweight is positioned safely on the LDU. It must be avoided that the counterweight may fall down from the LDU. If the counterweight cannot be securely fastened on the LDU, it is not allowed to use it in that combination and users need to find an alternative solution. Contact us if support is needed.

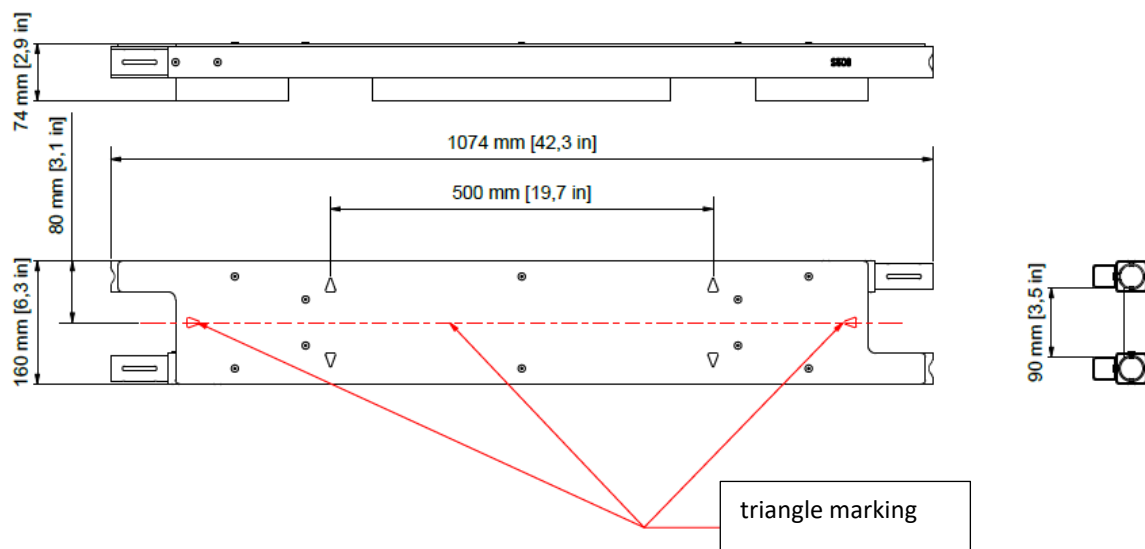
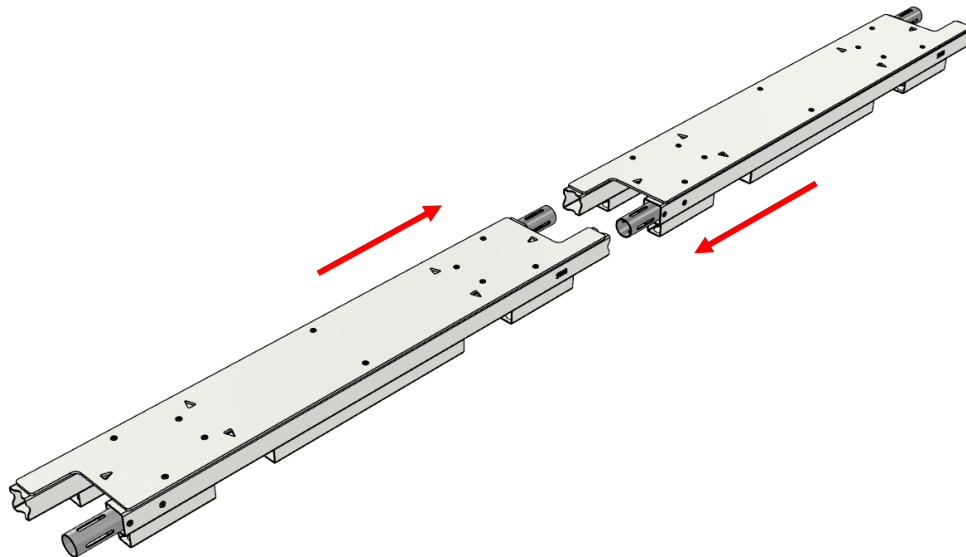

Figure 6 Exemplary drawing of LED-LDU-500

## Manual PLS (Professional LED Stacking)

---

The single parts of the LDU need to be connected by sliding them into each other. After that they can be placed on the extension. See following section for further details how to position the LDU on short or long extensions.

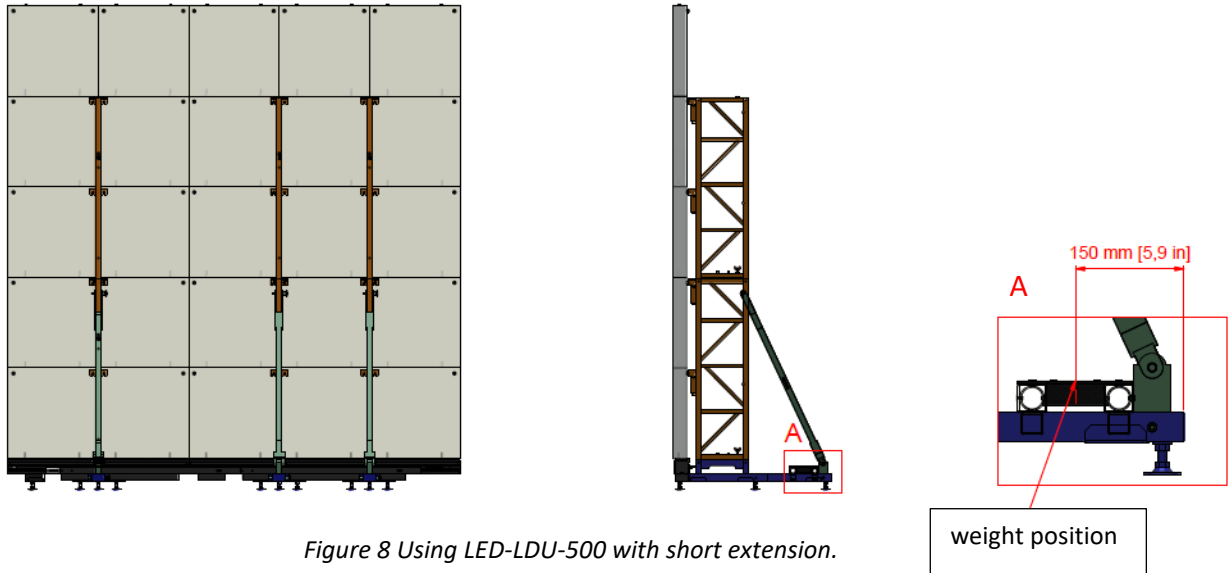

*Figure 7 Connecting two LDUs*

# Manual PLS (Professional LED Stacking)

## Using LDU in combination with short extension

Note: The following exemplary drawings are made with LED-LDU-500.



Position the LDU directly behind the diagonal like shown in Figure 8. This ensures that the counterweight's centre of gravity (COG) is positioned at the required distance of 150 mm (5.9 in) as specified by the static calculations.

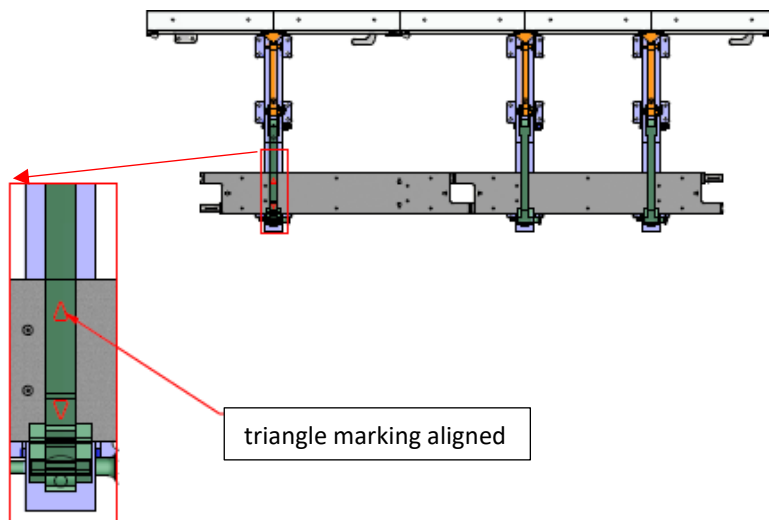

Figure 9 Using LED-LDU-500 with short extension (detail)

The LDU must be positioned with the triangle marking aligned with the centre of the extension (LED-EXN-S), as shown in Figure 9.

# Manual PLS (Professional LED Stacking)

## Using LDU in combination with long extension

Note: The following exemplary drawings are made with LED-LDU-500.

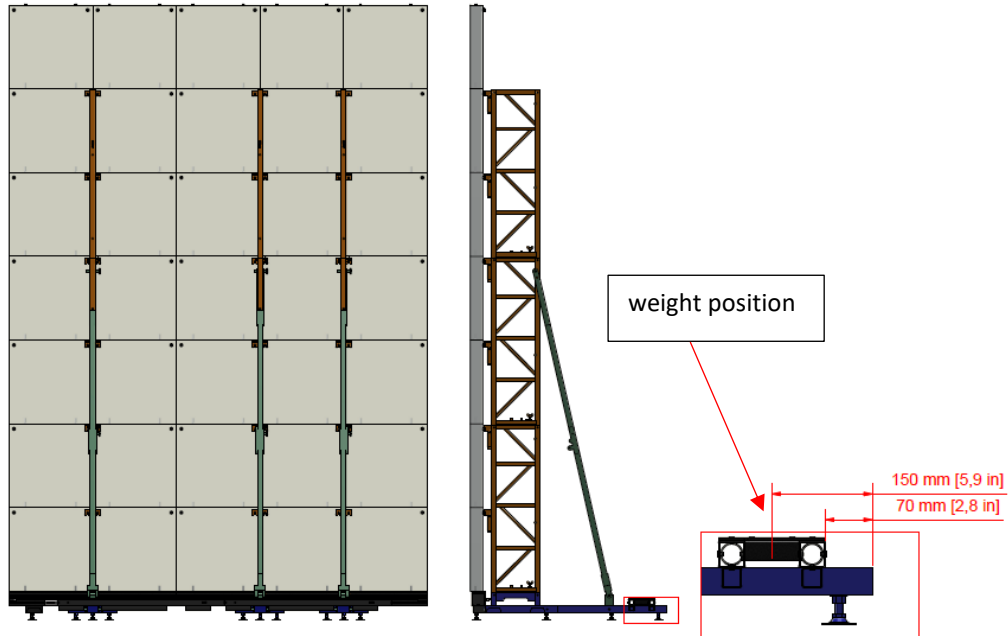

Figure 10 Using LED-LDU-500 with long extension.

Position the LDU approximately 70 mm (2.8-in) from the back of the LED-EXN-L. This ensures the counterweight's centre of gravity (COG) is positioned at the required distance of 150 mm (5.9 in), as specified by the static calculations.

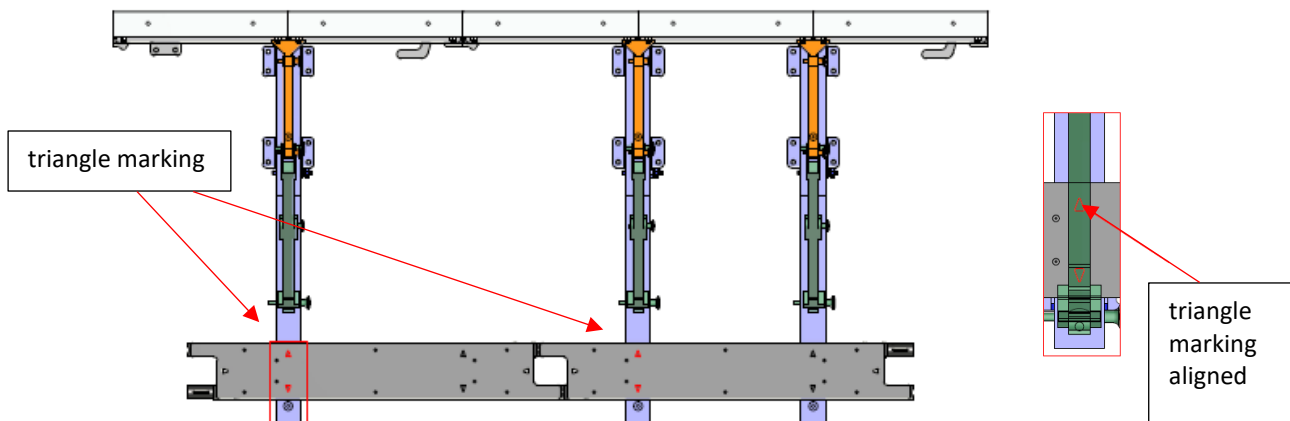

Figure 11 placing LED-LDU-500 to installation with long cantilever (detail)

The LED-LDU-500 must be positioned with the triangle marking aligned with the centre of the extension (LED-EXN-L), as shown in the drawing.

## 6.3 Horizontal support for STACKERS

For Setup Variant 4 and 5 additional structures for stiffening the STACKERs are necessary. This has to be done right on top of the second STACKER row. The STACKERs have suitable holes on their backside. See the red marking in Figure 12.

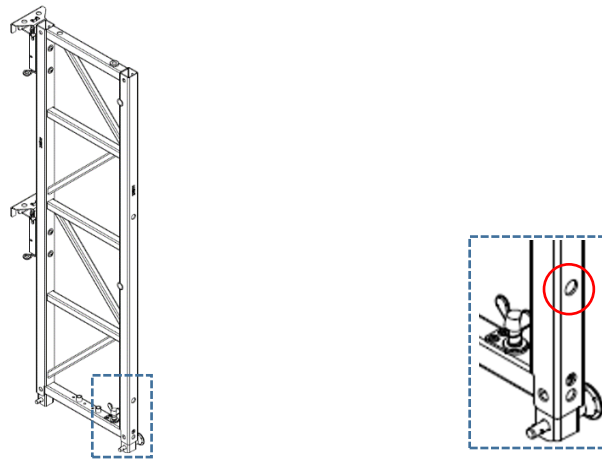

Figure 12 STACKER mounting hole

This can be done, for example, by using half couplers and pipes with a diameter of 50 mm. See Figure 13 as possible exemplary position for a horizontal pipe connection between the STACKER.



Figure 13 is just an illustration of one stacker column. Of course, multiple stacker columns need to be connected with a pipe construction.

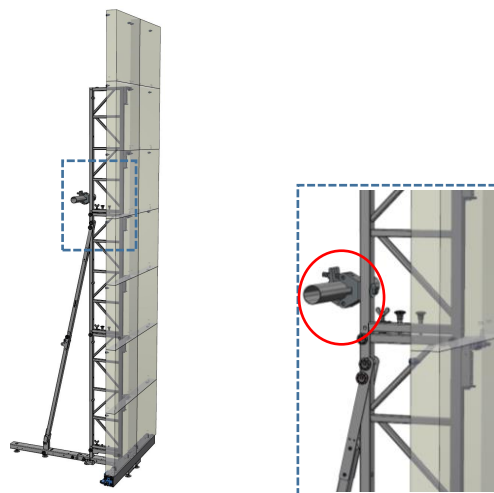

Figure 13 STACKER possible pipe position

## 6.4 Tensile connection to the ground

The tensile connection to the ground must be chosen correctly by following the static calculation. The setup variants 2, 4 and 5 do not require a tensile connection to the ground. For variants 2, 4 and 5 see chapter 6.2 Ballast weight.

The setup variant 1 requires a tensile connection to the ground.

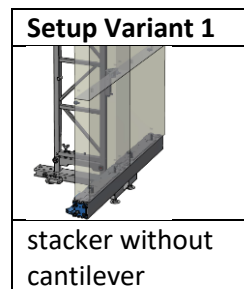

Table 2 Tensile connection to the ground

Figure 14 illustrates the anchor points at the SKI. There is one anchor point at the back and 4 anchor points at the front. The anchor points on the front are in two separate angle profiles each with two holes.

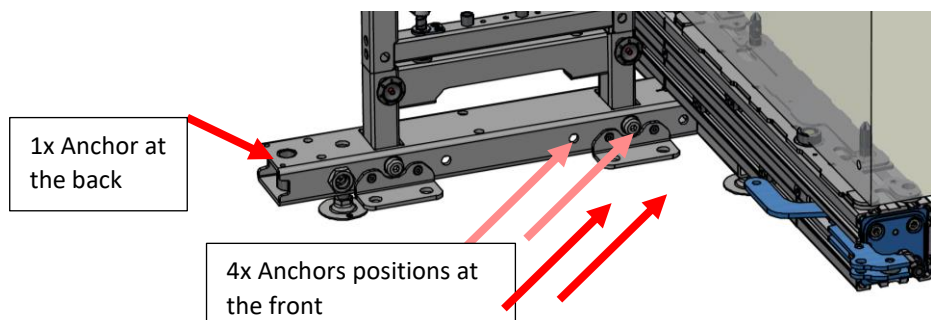

Figure 14 Detail tensile connection to the ground



It is mandatory to use at least one anchor point in both angle profiles at the front and the one anchor point at the back. See Figure 14.



The static calculation provides details on the forces that the anchor points need to be able to resist to. Make sure the anchor points are strong enough for the forces provided by the static calculation.

Additionally, to the tensile loads, the anchors must be dimensioned for a horizontal load of 0,5 kN. This horizontal load is calculated considering the possible impact of persons and the resulting forces. Those forces can be understood as shearing forces.



The anchor points must be able to resist the tensile loads provided in the calculation but also to a horizontal load of 0,5 kN (shearing force).



## 7. Maximum stacking information

Please refer to the static calculations of the corresponding LED cabinet to define maximum stacking information. Users need to define the given facts which are:

- Environmental conditions
- Size of the wall

With those information, users have to check the static calculations to figure out the resulting facts which are:

- Possible setup variant(s)
- Ballast weight

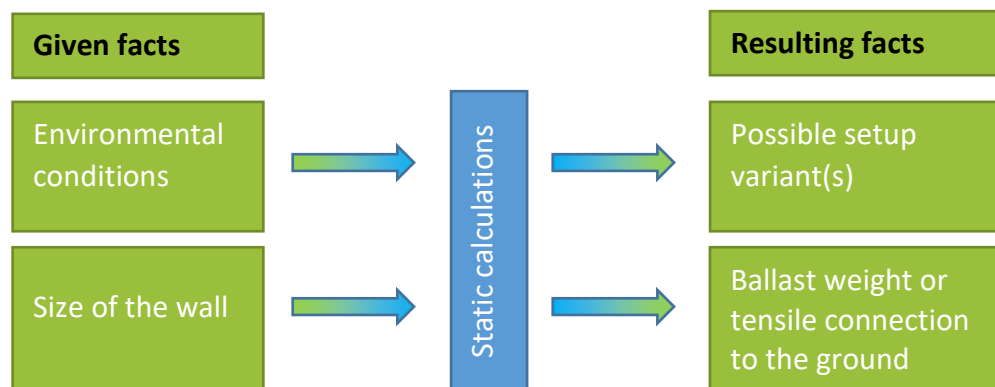

Figure 15 Flow chart determination of correct resulting facts



Do not exceed the maximum number of stacked LED cabinets that are defined in the static calculation depending on environmental conditions and size of the LED wall.



Do not undercut the needed ballast weight.



Make sure tensile connections to the ground are sufficiently dimensioned to resist the forces that are defined by the static calculation.



Make sure that the structure/surface where the LED Stacking system is built up, is capable of carrying the overall weight of the system plus the weight of all additional equipment as well as other potential systems.

## 8. Step by Step installation procedure



The SKI and possible SKI Extensions must always be firmly secured to the floor with fixings or stabilized with ballast. This is to prevent possible tip over and sliding of the LED wall due to external influences. The correct choice between tensile fixing to the ground or ballast depends on the installation variant and other factors. See chapter 6. Results of static analysis for details.

It is the responsibility of the installer to ensure the stability of the LED wall. Note that the stability of the LED wall depends on different parameters like: weight of display, height of display, width of display, length of used SKI and SKI Extension and Installation variant as well as condition and stability of the floor.

### 8.1 Prepare the installation

Make sure that the surface on which you want to build the LED wall is flat, clean and sufficiently stable to support the weight of the entire system as well as other potential loads. Eliminate any bumps and ensure a safe setup environment.

### 8.2 Installing the SKI and BASE

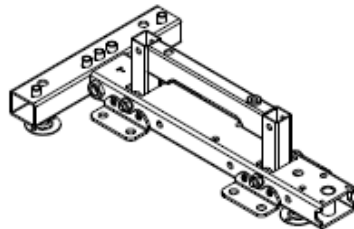

*Figure 16 SKI*

Place the desired number of SKI next to each other.

# Manual PLS (Professional LED Stacking)

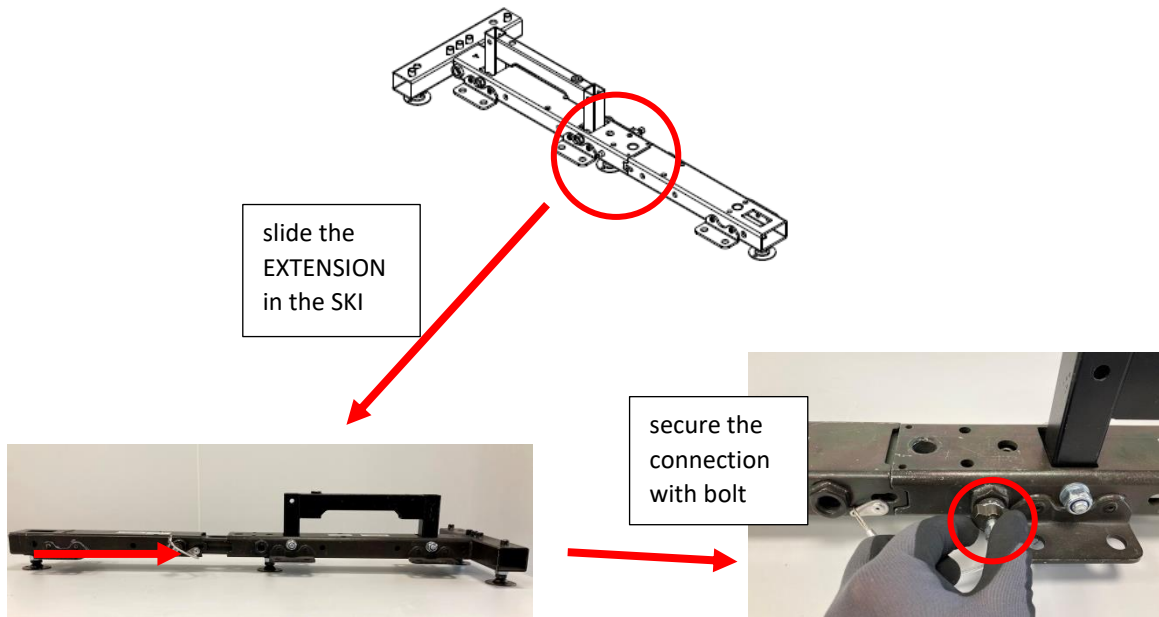

Figure 17 Assembly SKI and EXTENSION

Equip the SKI with the appropriate SKI Extension (S or L). To do this, slide the SKI Extension with the connector into the back of the SKI (In case of Setup Variant 3, slide into the front (see Table 1)). Secure the connection with the bolt on the extension and screw the connection tight. See Figure 17.

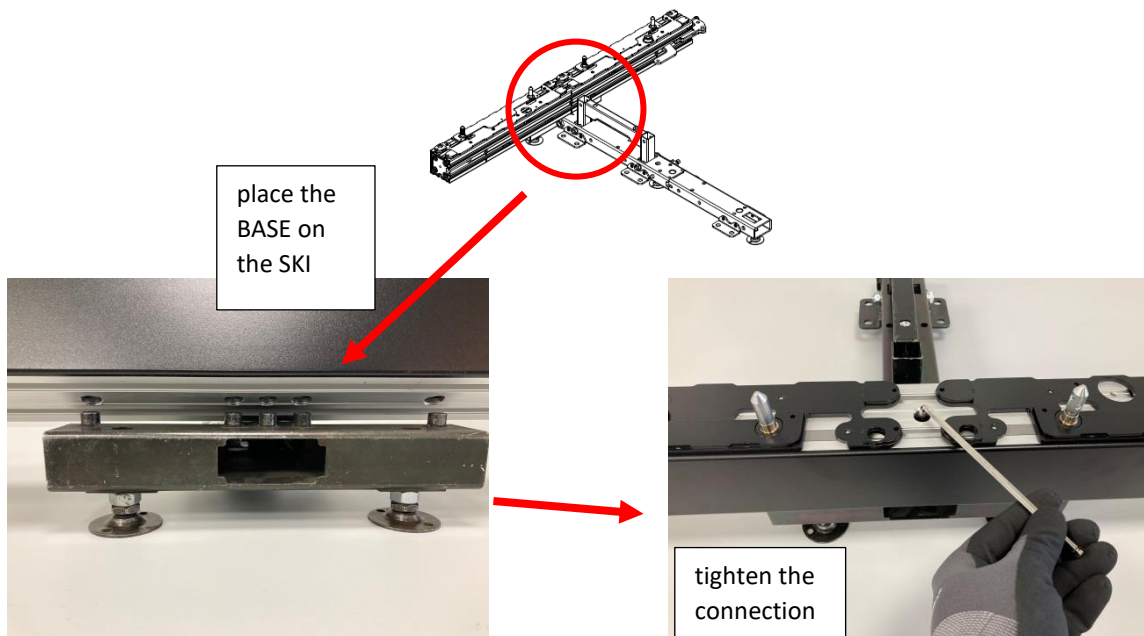

Figure 18 Assembly LED-SKI and BASE

## Manual PLS (Professional LED Stacking)

---

Start on one side by attaching the bases to the SKI. You need a 5mm Allen key for this. The position of the SKI (in the middle or at the connection of the bases) depends on the chosen installation variant. Align the ski with the attached BASE using a spirit level and a 6mm Allen Key. See Figure 18.

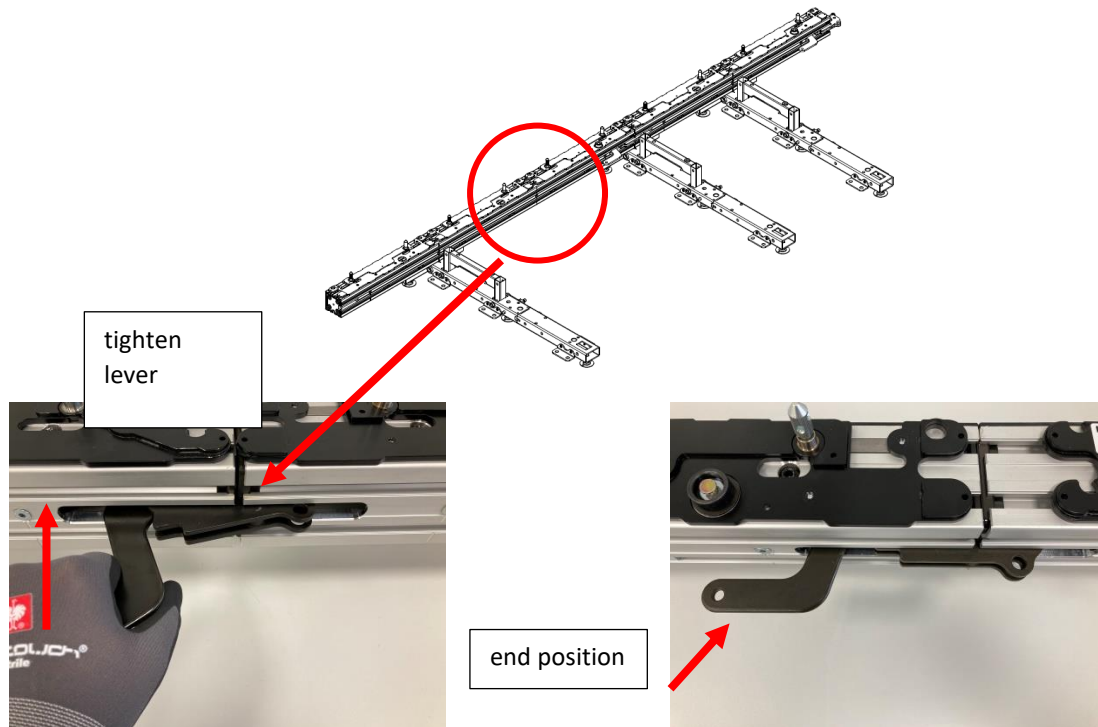

Figure 19 Assembling next SKI to the BASE

Now assemble the next BASE and the next SKI together and connect them to the first aligned BASE (Figure 19). The maximum distance between the SKIs or the stackers to be set up with them may not exceed the width of two LED cabinets. This means that a SKI and STACKER must be arranged at least behind every second joint of cabinets. Align both components again.

If you want to have a SKI on the connection of two BASES, first connect the BASES together, then install the SKI in the middle of the connection.

Proceed in this way until you have built the desired number of BASES. Make sure that the BASES and SKIs are precisely aligned at all times.

If the lever is very stiff or cannot be tightened at all, adjust the clamping by adjusting the screw on the clamping lever. Loose the locking nut by using the 13mm hexagon wrench key. Adjust the clamp-screw. Try the connection. It should be possible to make the connection

## Manual PLS (Professional LED Stacking)

---

with force, but not with too much force. When the connection is satisfactory tight, secure the position of the clamp-screw with the lock nut again. See also Figure 20.

Secure the complete SKI-BASE-Setting with the nuts on the adjustable feet of the SKI to prevent it from loosening. For this you need the 19mm hexagon wrench key.

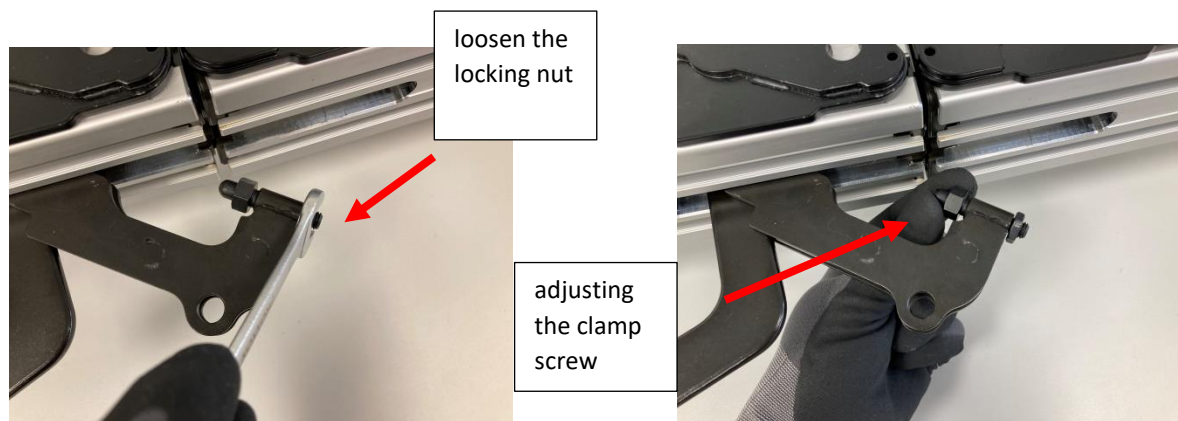

*Figure 20 Adjusting the lever*

## 8.3 Connecting the STACKER

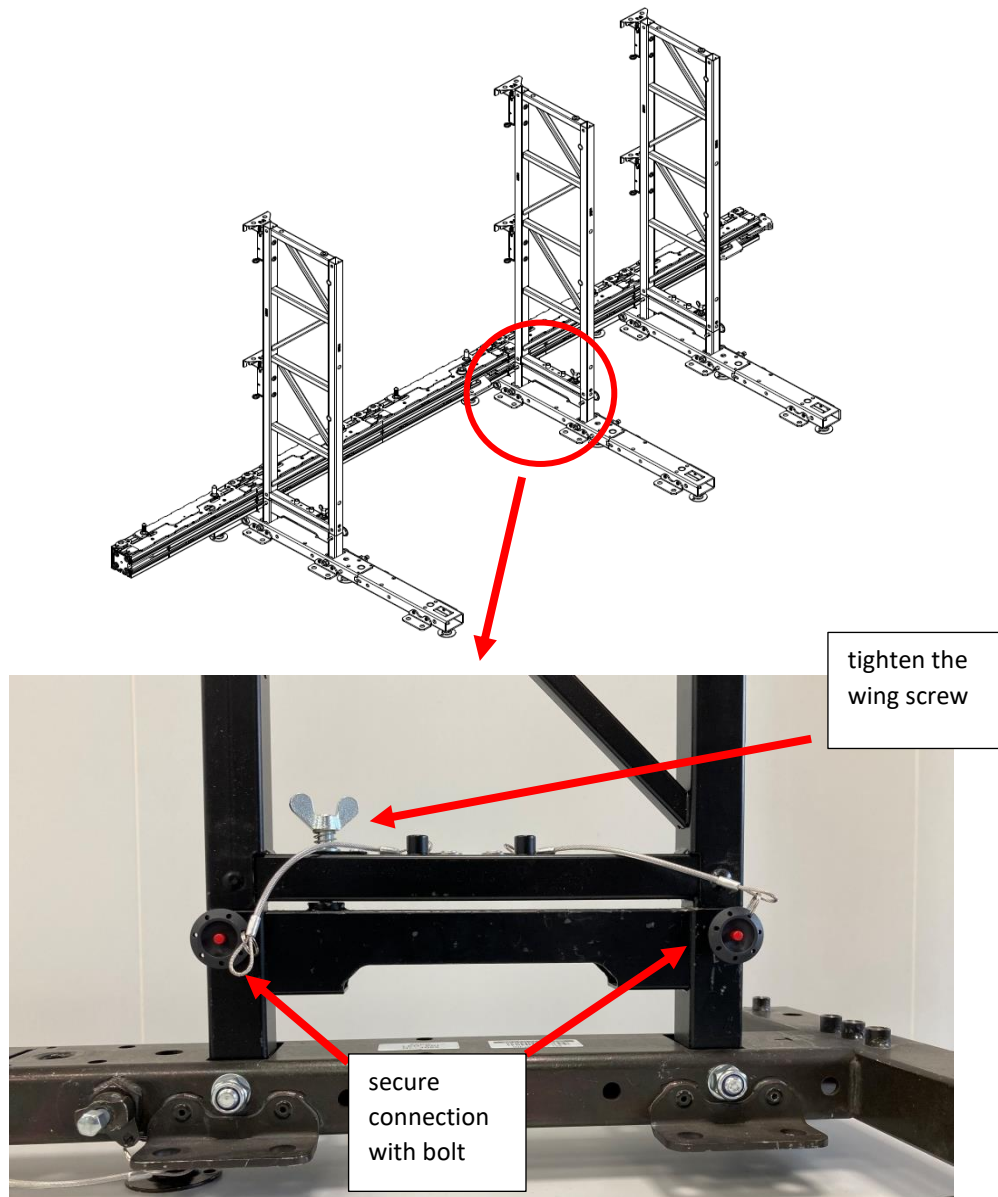

Figure 21 Assembling the STACKER



**STACKERS must be arranged at least behind every second joint of LED cabinets.**

Insert the STACKER into the openings provided on the SKI and secure the connection with the bolts connected to the STACKER. Now tighten the wing screw. Proceed in exactly the same way when connecting STACKER on STACKER. See Figure 21.



### 8.4 Installing the LED cabinets

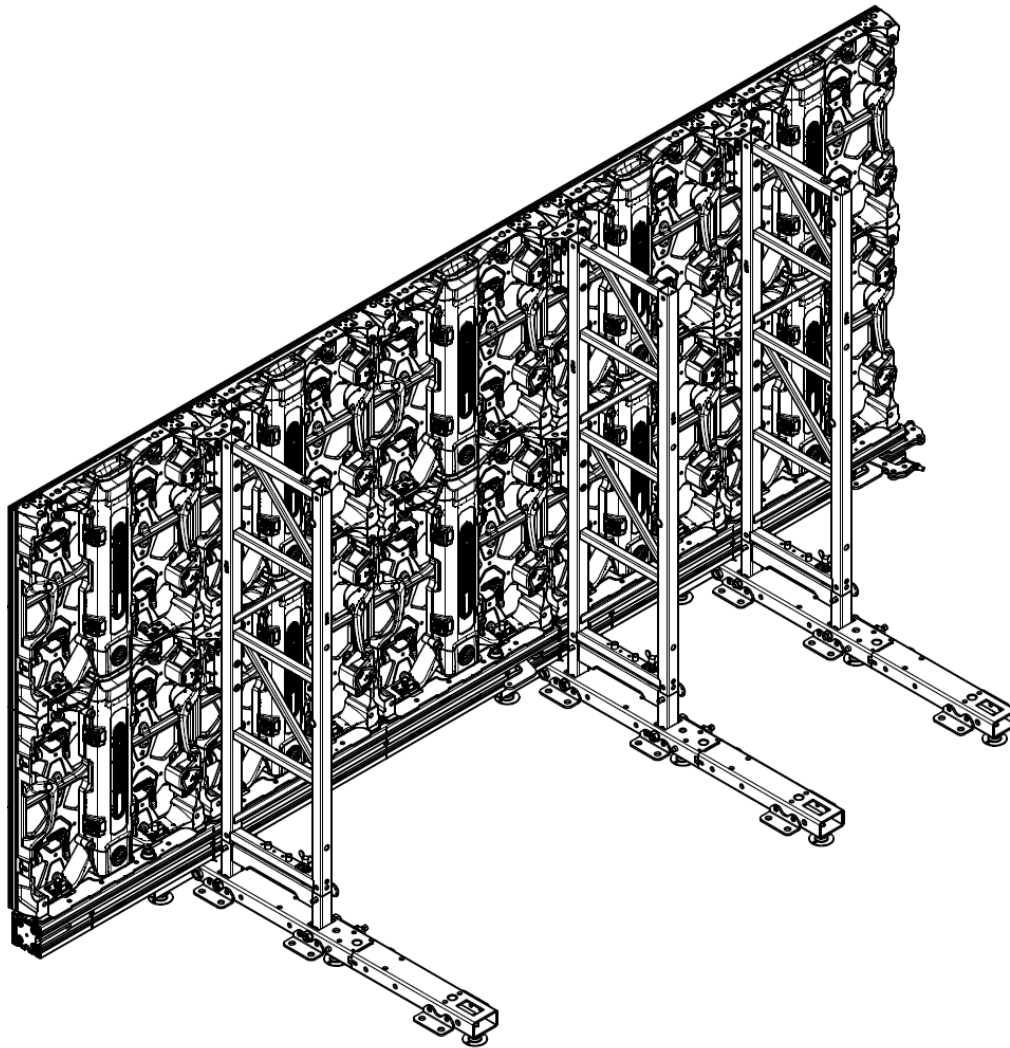

*Figure 22 overview LED cabinets and LED CLP stacker clamps*

Start assembling the LED cabinets. Place the LED cabinet on the connection points of the BASE Plate and lock the connection. Align the LED cabinet with the movable BASE plate. Now place the second LED cabinet in the same way and connect both LED cabinets with each other. Now lock the BASE plate. Ensure that the LED cabinets are securely connected to each other and to the BASE Plate. Continue in this way until the bottom row is completely assembled. Figure 23

## Manual PLS (Professional LED Stacking)

---

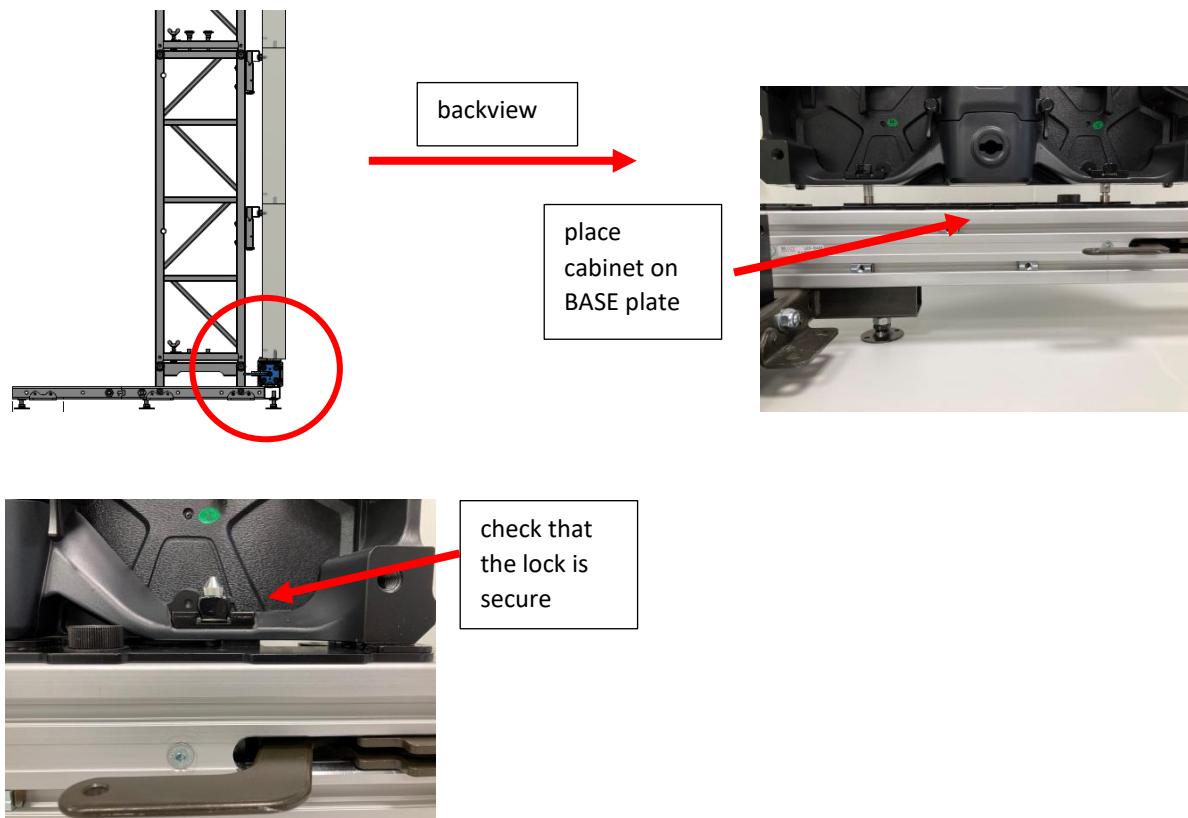

Figure 23 assembling LED cabinet (exemplary Infiled DB series)

Now attach the CLAMP to the STACKER and LED cabinet by pushing the CLAMP from the top into the fastening tube on the STACKER. Insert the claws on the CLAMP into the groove of the screws of the SCREW Set which are mounted to the LED cabinet. Push the CLAMP downwards through to the end and secure it with the split pin provided. See Figure 24.

Now assemble the second row of LED cabinets. Always make sure that the LED cabinets are securely connected to each other. Next, attach the second row of CLAMPS as previously described.

Continuously check the alignment of the system during assembly.

Place the counterweight on the SKI as previously described in **7. Maximum stacking information**, if needed (depends on the setup variant).

Also depending on the setup variant (variant 4 and 5), install the Diagonal as described in **8.5 Installing the DIAGONAL** after 2<sup>nd</sup> or 4<sup>th</sup> row.

Continue with the installation as described until you reach the desired height. Place a STACKER for every two LED cabinet heights. The last top row may be installed without STACKER.



## Manual PLS (Professional LED Stacking)



Never exceed the maximum number of stacked LED cabinets specified by the manufacturer!



Do not exceed the maximum number of stacked LED cabinets that are defined in the static calculation depending on environmental conditions and size of the LED wall.

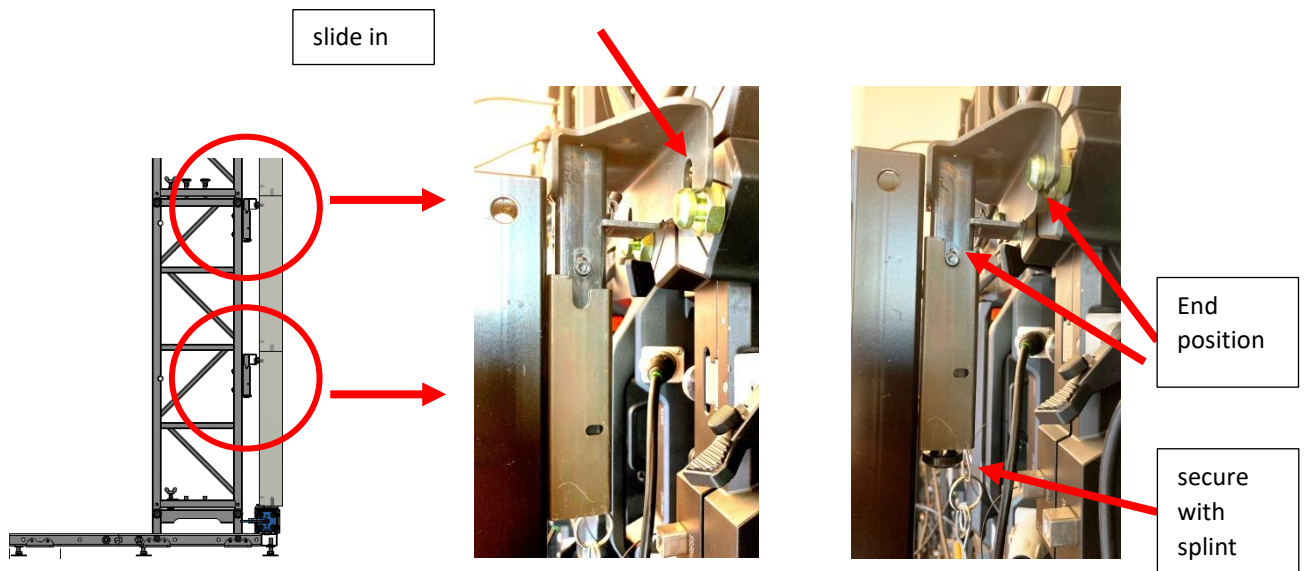

Figure 24 Attaching the STACKER clamp



Note: The knurled screw in the base plate should be tightened prior transport. Furthermore, it is helpful to tighten only the screw of the base plate which is close to the centre of the whole wall. This makes sure that the centre of the wall remains in the desired position for example due to mechanical extension caused by temperature fluctuations.



Figure 25 Knurled screw at base plate

### 8.5 Installing the DIAGONAL

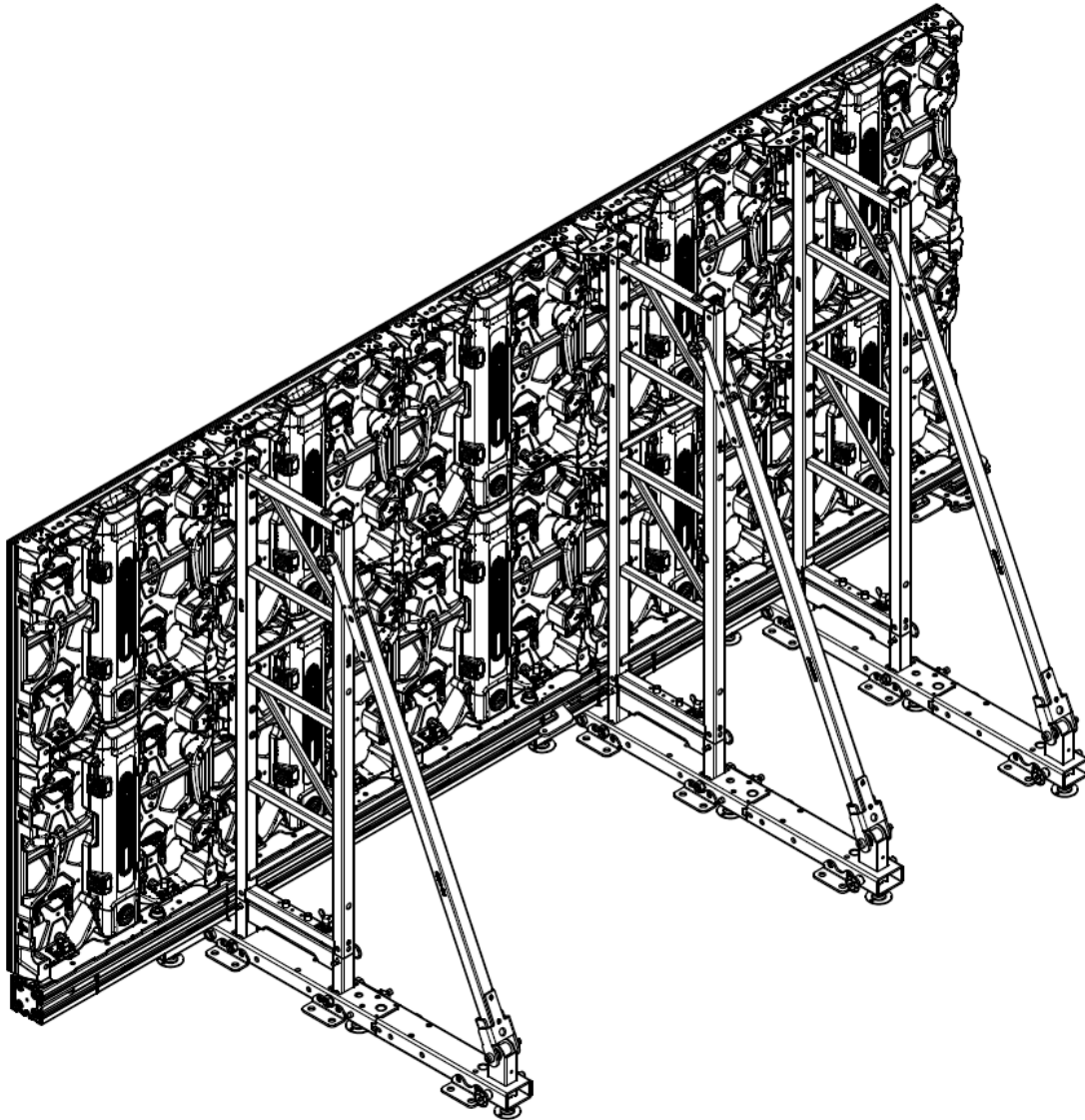

*Figure 26 Overview DIAGONAL on STACKER*

Depending on the installation variant, install the DIAGONAL after the second or fourth vertically installed row.

To do this, insert the lower connection part into the opening of the SKI extension and secure the connection with the mounted bolt.

Now fold the upper part of the DIAGONAL towards the STACKER until the fork opening slides over the stacker and can be secured with the mounted bolt. Make sure that the bolts are seated securely and accurately and are secured against loosening. Figure 27

# Manual PLS (Professional LED Stacking)

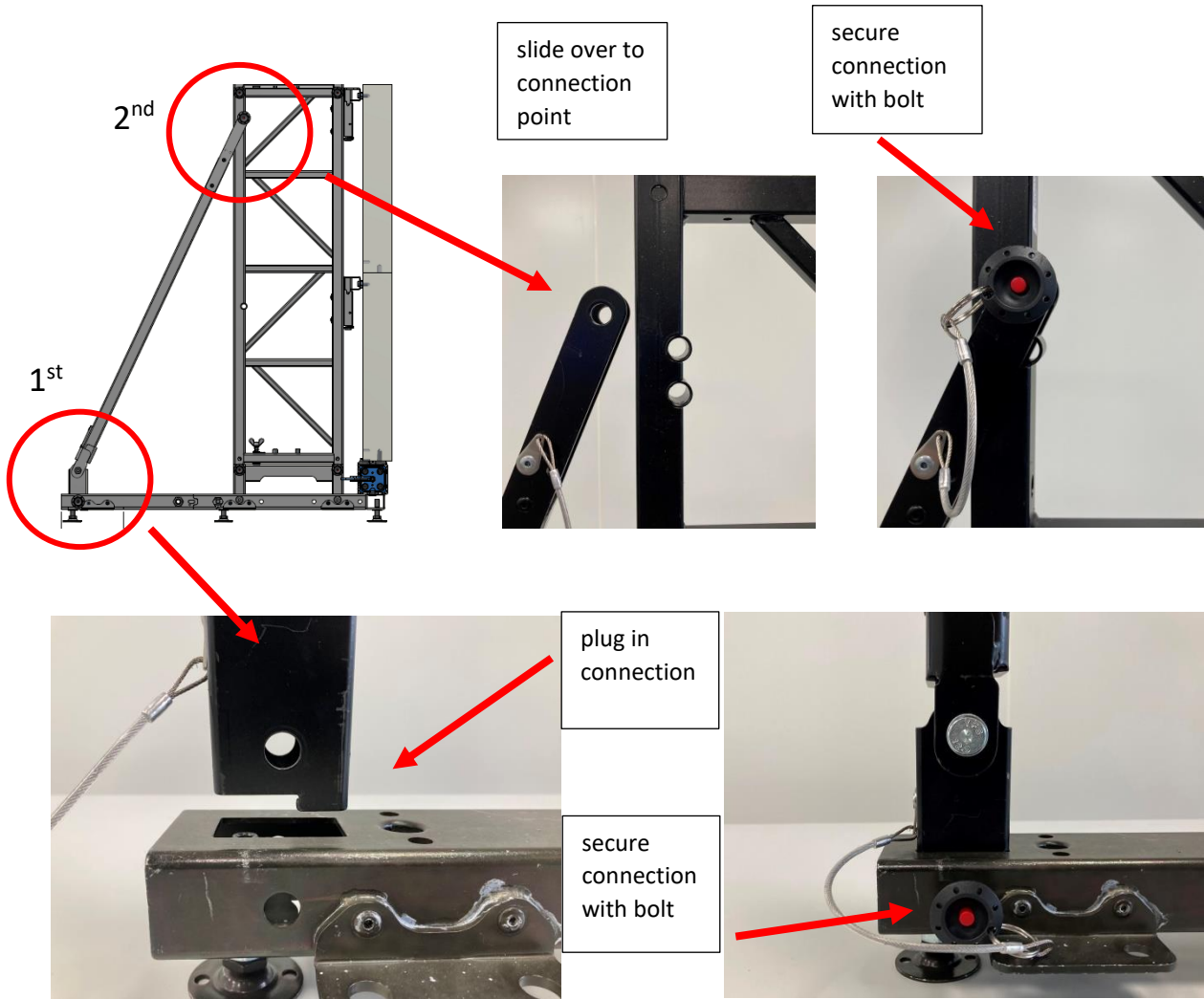

Figure 27 Assembling DIAGONAL to STACKER

### 9. Curved Walls

Curved walls, or more specific, angled walls are a special case.

There is a need to consider two variants here:

Variant 1: Walls where the used LED products offers a solid connection between the cabinet, ensuring stability and consistency. These LED products have a standard connection mechanism between the horizontal points of cabinet junctions, allowing for adjustable angles such as  $-5^\circ$ ,  $-2.5^\circ$ ,  $0^\circ$ ,  $.5^\circ$ , and  $5.0^\circ$ . Given that this connection is provided by the LED cabinet manufacturer, it can be assumed that it can withstand the expected forces.

When building curved or angled walls using these connections, follow the same principles as for flat walls, ensuring the cabinets are used correctly and securely fastened. Important principles include following to weight distribution rules, maximum wall height, and proper stacker placement.

Variant 2: Walls without a solid connection between LED cabinets makes it necessary to treat each column as an independent wall unit. This means that behind each LED cabinet column, a separate stacker column is mandatory. It is not allowed to skip Stacker columns. Furthermore, counterweight must be placed and calculated accordingly. If the static calculation demands for a horizontal support for the stackers, see also chapter 6.3 **Horizontal support for STACKERS**, the installing person / company needs to find a suitable solution or it is not allowed to set up that specific wall.

This approach ensures structural integrity and support for the entirety of the wall.



## 10. Exemplary LED walls

### 10.1 Infiled DB Series 15 by 10

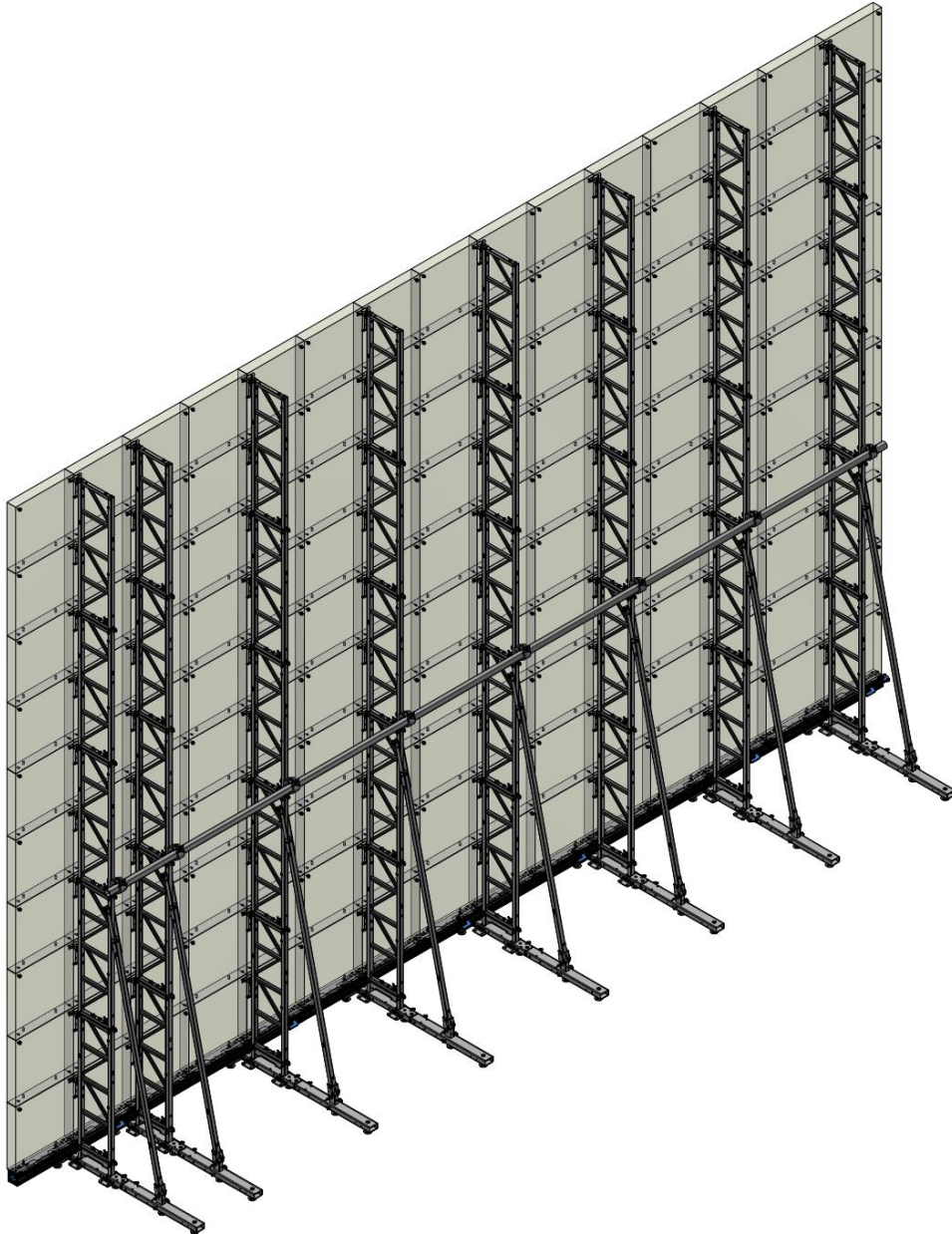

Figure 28 DB Series 15x10 Isometric View



Note: For a wall with uneven number of cabinets in the width (e.g. 15), there will be two adjacent stacker columns in an installation. The position of these adjacent stacker rows can be at any place of the wall as convenient. It is mandatory to avoid having more than one joint between two cabinet columns without a Stacker column.

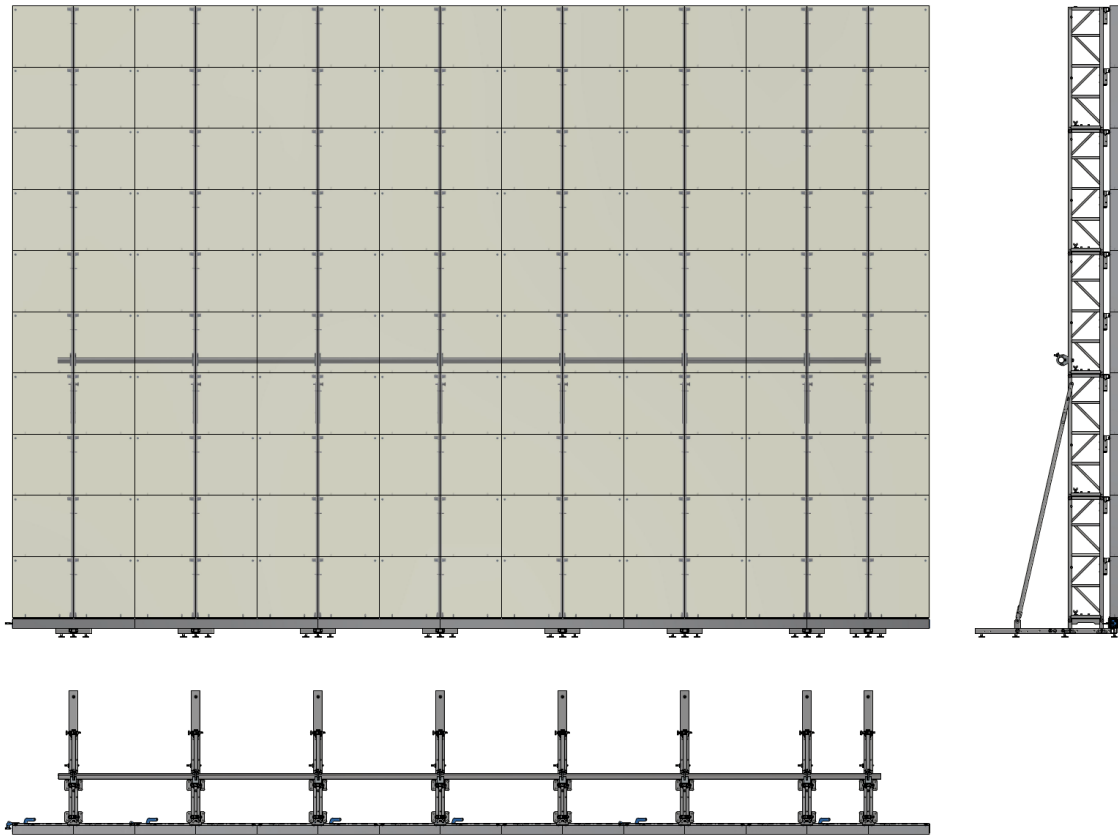

Figure 29 DB Series 15x10 Views

This exemplary wall has a width of 16 and a height of 10 LED Cabinets Infiled DB Series.

Article		Count
SKI	LED-SKI	8
SKI Extension Long	LED-SKI-EXN-L	8
BASE Profile double + BASE Plates	LED-B500-2-ILDB	3
BASE Profile triple + BASE Plates	LED-B500-3-ILDB	3
STACKER	LED-STR-500	40
CLAMP	LED-CLP-ILDB	80
SCREW Set	LED-SRES-M10Zn	Min. 80
DIAGONAL Long	LED-DIL-L500	8

Table 3 Articles in 16x10 Infiled DB Series Wall

What is not listed in Table 3 is:

- Counterweight depending on results of static analysis
- Horizontal pipe and clamps over second row of STACKER

## 10.2 Absen AXpro 14x14

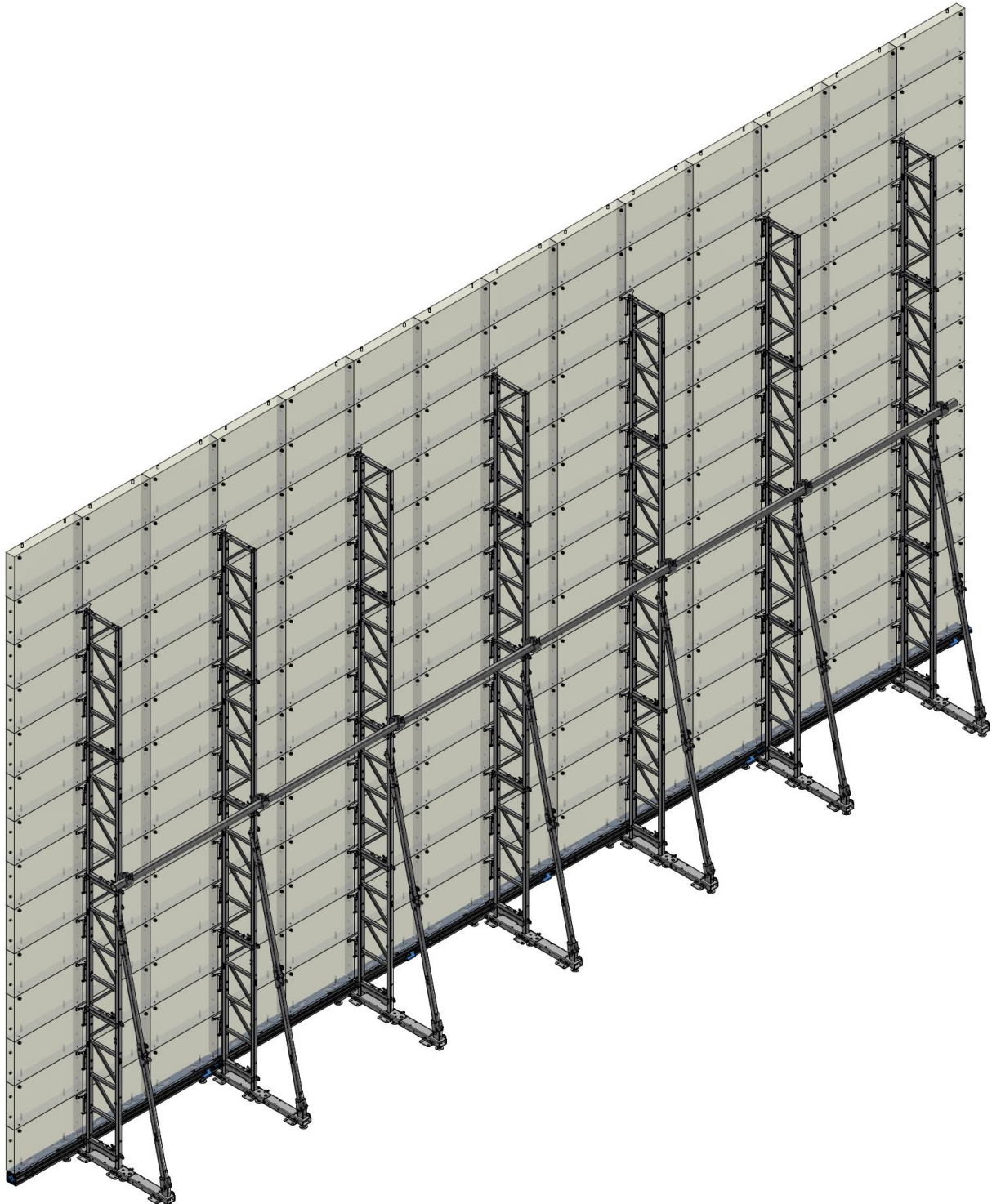

*Figure 30 Absen AXpro 14x14 isometric view*

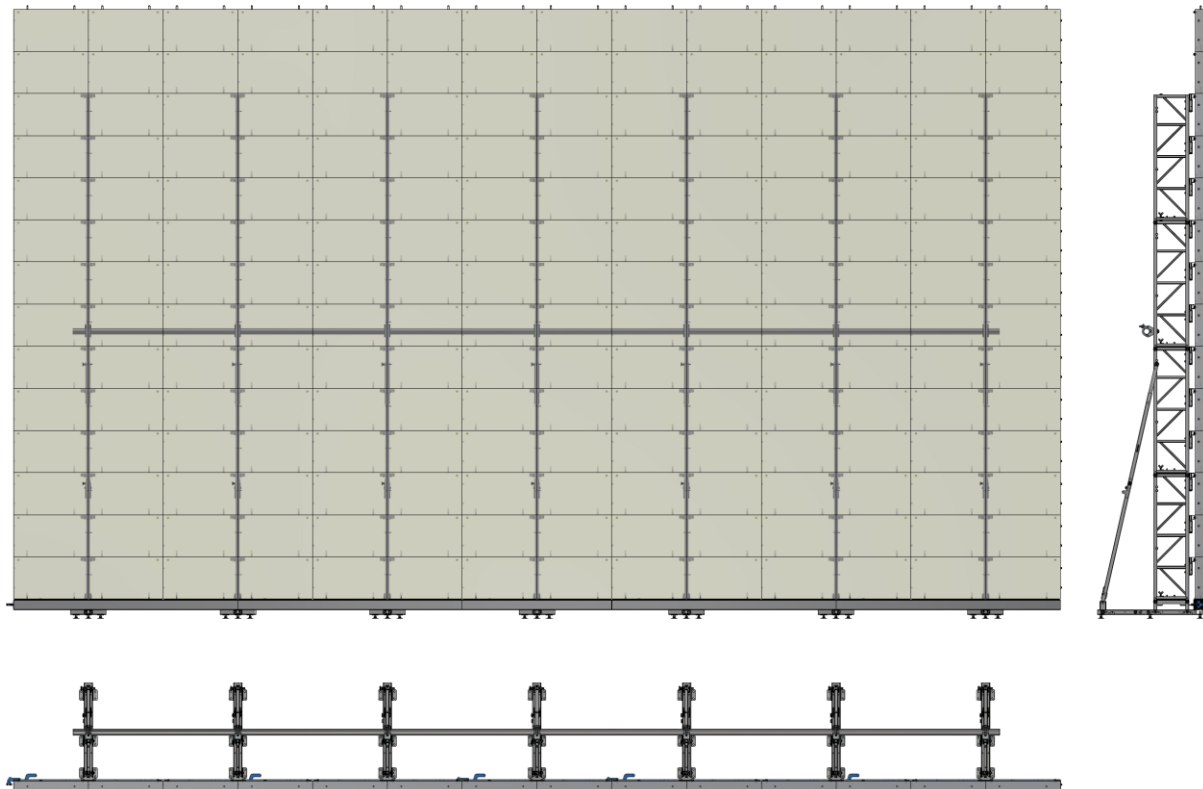

Figure 31 Absen AXpro 14x14 Views

This exemplary wall has a width of 14 by 14 LED Cabinets Absen AXpro.

Article		Count
SKI	LED-SKI	7
SKI Extension Short	LED-SKI-EXN-S	7
BASE Profile double + BASE Plates	LED-B500-2-ILDB	1
BASE Profile triple + BASE Plates	LED-B500-3-ILDB	4
STACKER	LED-STR-500	28
CLAMP	LED-CLP-ILDB	84
SCREW Set	LED-SRES-M10Zn	Min. 84
DIAGONAL Long	LED-DIL-L500	7

Table 4 Articles in 14x14 Absen AXpro Wall

What is not listed in Table 4 is:

- Counterweight depending on results of static analysis
- Horizontal pipe and clamps over second row of STACKER



### 11. System maintenance and inspection re-examination



For all components of the LED Stacking a visual inspection must be done prior to every installation in which the system is involved. The inspection must be done by a qualified person!



**Periodic inspections are mandatory.** Depending on local laws and regulations owners / users must do periodic inspections of the products and all components. It is recommended to do this once a year by a qualified and authorised person.



Note: The necessary inspections can also be done by the manufacturer.



Do not exchange broken or malfunctioning parts with ones that are not approved by the manufacturer because serious injuries and property damage can occur!



If any parts are broken or missing stop using the product, please contact the seller so he can provide the spare parts. Do not replace any parts on your own.

Make sure that no part of the LED Stacking System shows any kind of damage such as:

- Bending
- Dents
- Corrosion
- Cracks
- etc.

Check each part of the LED Stacking system to ensure that all needed mounting material is available. This mounting material is for example:

- Locking pins
- Wing screws
- Height adjustable feet
- Bolts
- Splints
- etc.

The basic mechanical design of the Stacking Systems tries to avoid mounting material to get lost. This is done by for example securing them with steel cables to the main parts.

## 12. Disposal of components

### 12.1 Metal parts and packaging

All metal parts and packaging can be recycled.

### 12.2 Disposal of entire devices

You have the possibility to send old devices back to us. Please note that you have to take over the transportation costs for this. Please send the devices to:

EXACT solutions GmbH

Lustheide 85

51427 Bergisch Gladbach

GERMANY

## Imprint

EXACT solutions GmbH

Lustheide 85

51427 Bergisch Gladbach

GERMANY

Tel.: +49 2204 9485 30

E-Mail: [info@exactsolutions.de](mailto:info@exactsolutions.de)

Web: [www.exactsolutions.de](http://www.exactsolutions.de)

